



# BKRS – walkable cable tray system

Effective protection for power supply cables and working people in industrial environments

# Stable and safe throughout day-to-day industrial work

## BKRS – walkable cable tray system

In hard, everyday industrial work, materials must be able to withstand all kinds of loads. This also applies to the electrical installation. Powerful protection against footfall, dust and many other loads is essential for supplying the systems with power and data reliably.

For these requirements, OBO offers its walkable BKRS cable tray system. The system is designed for the highest loads, which frequently occur in the vicinity of machines and automated production systems with robotic elements.

Our BKRS system is already utilised by the giants of the automotive industry and features approvals in the factory standards of:

- BMW Group
- Volkswagen AG
- Volvo Car Corporation
- Jaguar Land Rover Ltd.
- Mercedes-Benz Group
- Ford

### System sizes

The BKRS cable tray is available with the side heights 100 and 110 mm. The dimensions and materials mean that they satisfy the guidelines and requirements of numerous industries. With six widths between 100 and 600 mm available, there is a suitable cable tray system for every possible application.





## Safe power and data supply for the industry sector

Automated production lines and systems construction applications consume very large quantities of energy and data, and hence require numerous cables. OBO's walkable cable tray system offers effective protection for the numerous supply cables required.

**UL-certified  
NEMA VE 1**





06 System overview

08 Anti-slip properties

09 Load capacity

10 Cover fastening

12 Duct stand-offs

14 EMC protection & dust protection

16 Equipotential bonding

20 Accessories

22 International presence

# The walkable cable tray system at a glance

Side height 100 mm

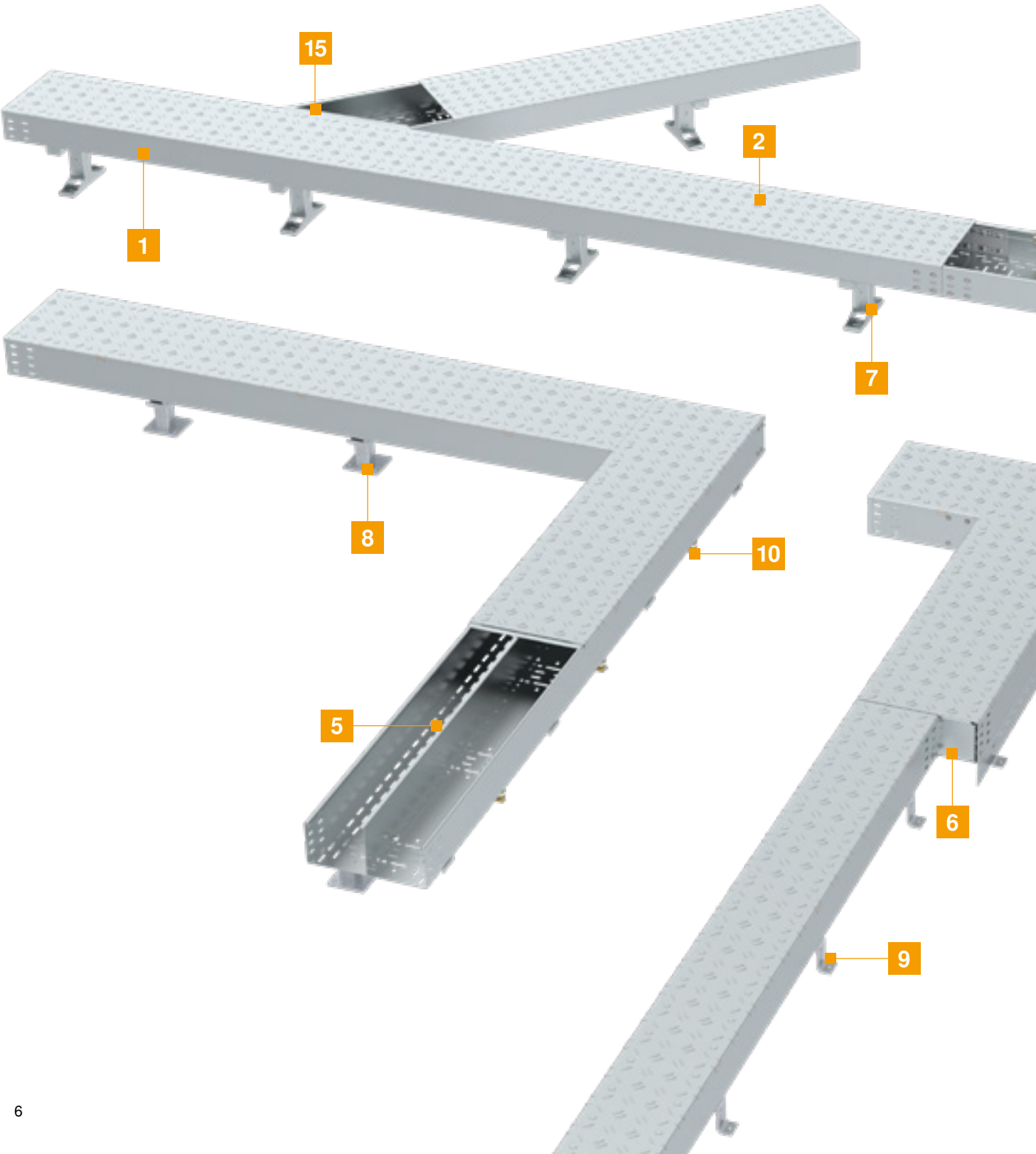

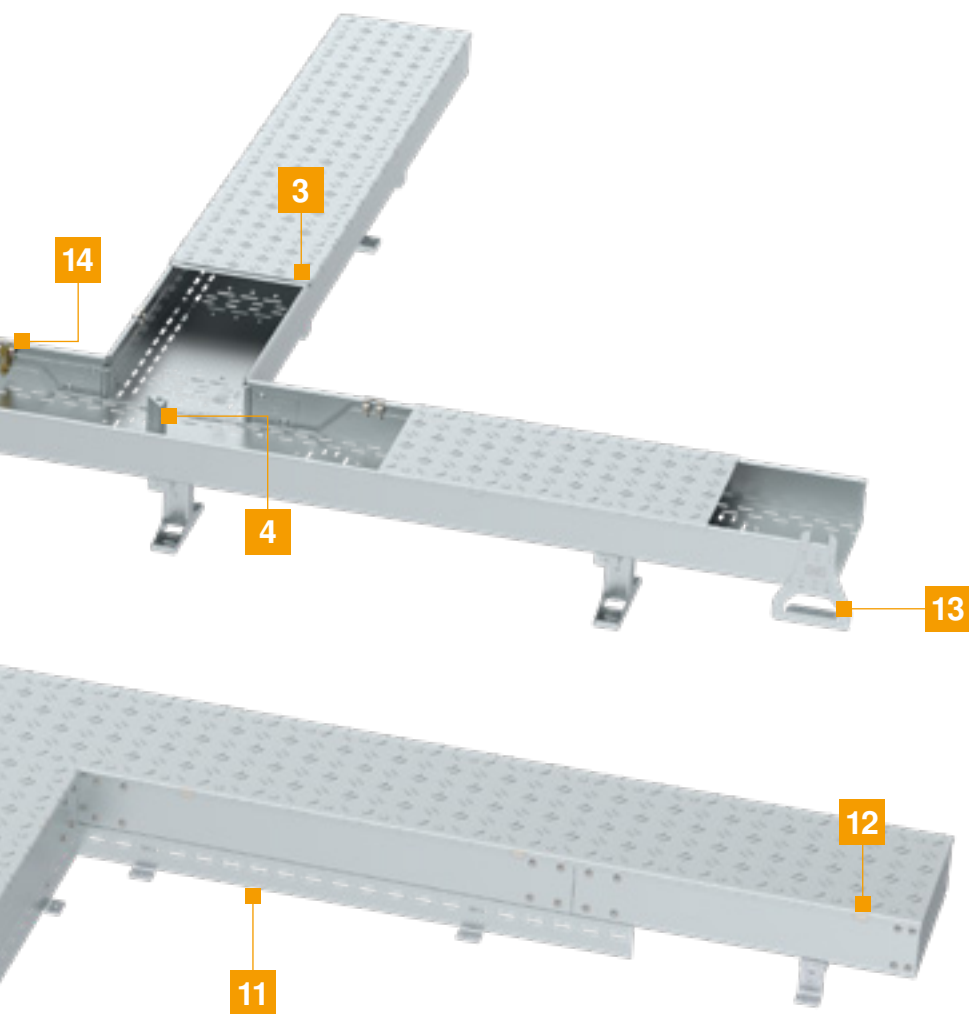

- 1** BKRS cable tray
- 2** Chequer plate cover
- 3** Dust protection element
- 4** Cover support
- 5** Z-shaped barrier strip
- 6** Reducer and stop-end
- 7** Symmetrical floor support
- 8** Support bracket
- 9** Z support + crossbeam for Z support
- 10** Connection terminal below the system
- 11** Protective panel for Z support
- 12** Cover clamp
- 13** Cover lifter
- 14** Clamp spring for conductor cable and connection terminal
- 15** Variable dust protection element

Side height 110 mm

# Protection at every turn

## Slip protection and displacement area

The slip and step protection of the covers is immensely important for safe working on walkable cable trays. The newly developed chequer plate arrangement of the BKRS cover ensures stability through optimum slip protection, minimising the risk of accidents in daily use.

The required classification is dependent on the place the cover is used and is described in BGR 181 "Floors in working areas with slippage risk" and ASR A1.5/1.2 "Technical rules for workplaces". The slip prevention of the covering surface is tested to DIN 51130 "Testing of floor coverings – Determination of the anti-slip property" with the ramp test walking method. Here, the slip prevention is tested on a ramp with different angles of inclination from 6° to > 35° and assigned according to the evaluation groups R9 (lowest requirements) to R13 (highest requirements).

The DBKR chequer plate cover fulfils the requirements of BGR and ASR and with its certified anti-slip properties it is

suitable for most environments that are walked on and have a risk of slipping.

If, due to the use of the building, extreme soiling with slippery substances (e.g. oils, animal fats, etc.) is to be expected, the surface must provide an appropriate displacement area for those substances in order to ensure that walking on the surface is safe.

The specification is done using the designation "V" in connection with the index for the minimum volume of the displacement area. Here, the scale ranges from V4 (displacement volume: 4 cm<sup>3</sup>/dm<sup>2</sup>) to V10 (displacement volume: 10 cm<sup>3</sup>/dm<sup>2</sup>). In this respect, the BKRS chequer plate cover surpasses the demands of most industries of V4 with a valuation group of V10.

### Advantages at a glance:

- Safe, anti-slip entry and exit due to corrugation on the cover and cover edges
- Certified anti-slip class R11
- Certified displacement space class V10



# Tested for maximum load capacity and high load-bearing capacity

## Mechanical load capacity

Heavy loads, stamping feet, dirt, dust – OBO's enclosed, walkable cable tray systems can handle all this and more, thanks to their ingenious system design and protect cables against damage. And all systems provide optimal shielding to ensure electromagnetic compatibility. Through the use of a barrier strip, power, control and data cables are insulated according to DIN EN 50174, to ensure electromagnetic compatibility. The trays and covers themselves provide perfect all-round protection for the cables. The cable tray, cover and barrier strips have a continuous material thickness of 2 mm and are highly mechanically stable as a composite.

In our in-house BET Test Centre, OBO simulates the loads that the walkable cable tray system has to withstand on a constant basis. We determine the maximum load capacity and carrying capacity of the system, as well as its resistance

to dust and corrosion. In other words, OBO places paramount importance on safety. The walkable cable tray system corresponds to the valid product standard IEC 61537 – Cable management, was tested according to all the relevant standards and, with the strip galvanised chequer plate cover, guarantees – depending on the installation type and subject to compliance with the mounting specifications – a footfall load of at least 350 kg according to EN 50085-2-2.

In order to ensure a safe maximum step load, the compartment size of 220 mm must be adhered to for the cable tray. This means, one mounted barrier strip is sufficient for a tray width of up to 300 mm, while at least two barrier strips need to be used for a width from 400 mm.



# Cover fastening

The cover is fastened with a cover clamp or turnbuckle.

The cover clamp was designed specifically for the chequer plate cover. The cover clamps can be quickly and easily applied to the clearly marked, predetermined fixing points, enabling straightforward mounting of the chequer plate cover onto the trunking. The cover can be removed from the cable tray using two cover lifters.

The turnbuckles allow the cover to be fastened without screws. They can be installed every 100 mm using the prepared knock-outs in the cover. At a cover length of 3 m at least 6 turn buckles should be used for fastening, 3 turn buckles per each side.

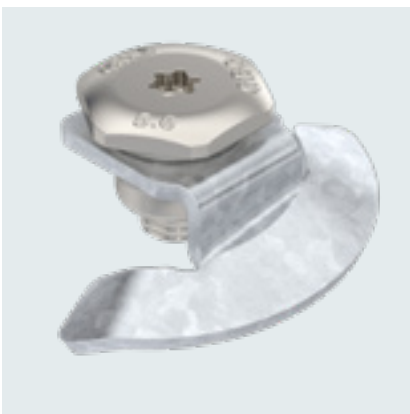

Turn buckle

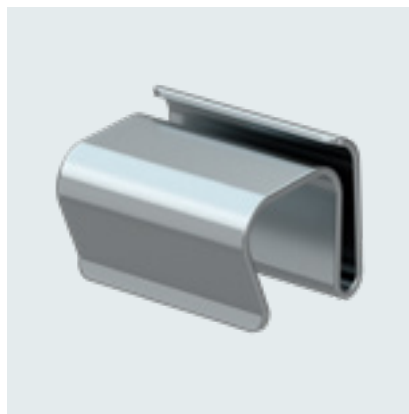

Cover clamp



Chequer plate cover DBKR



Cover clamp

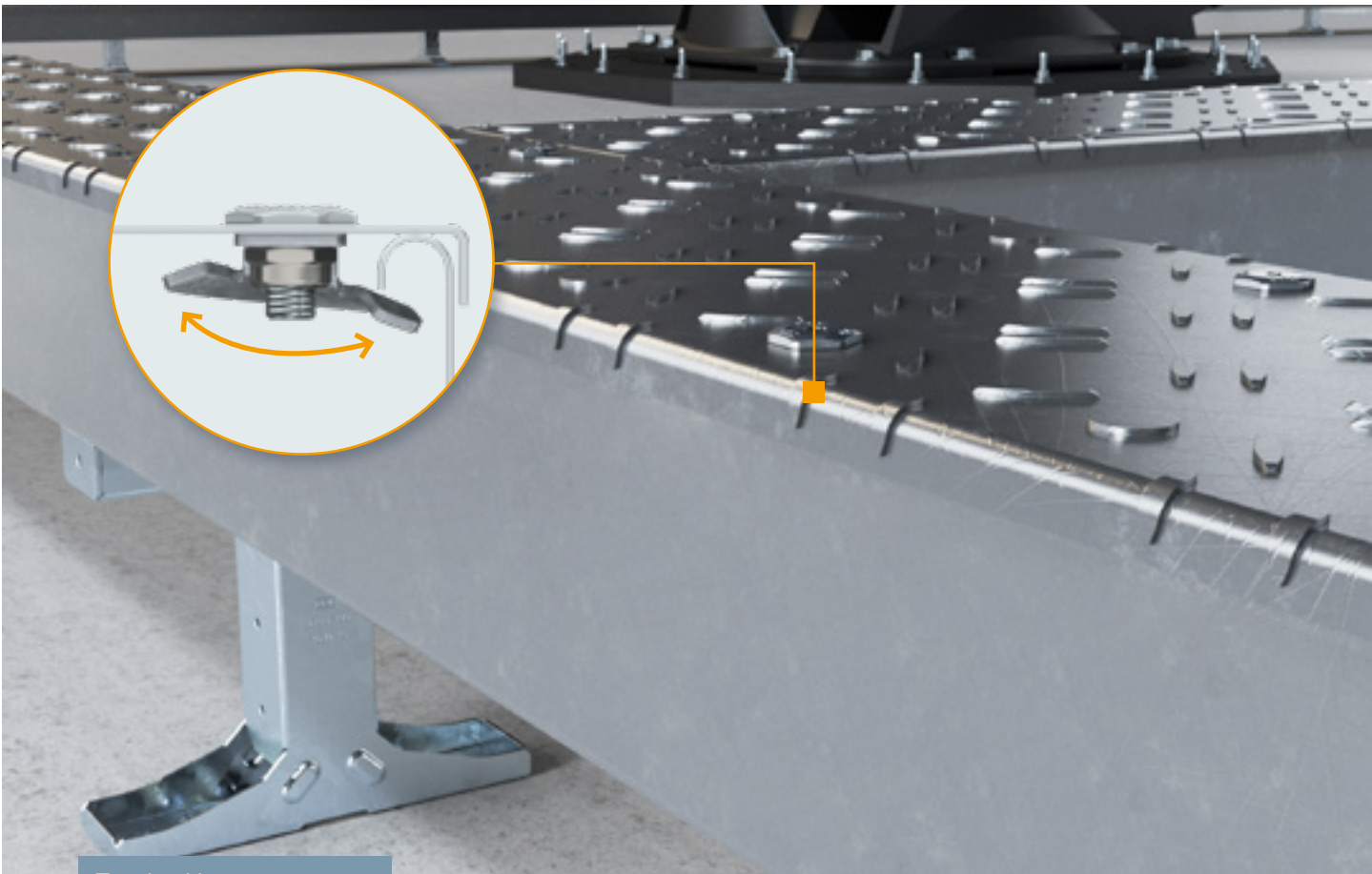

Turn buckle

# Duct stand-off

OBO is listed and approved by many renowned automotive manufacturers in Germany and abroad. To meet the wide-ranging needs, we offer standard and various manufacturer-specific and approved stand-off mounting support solutions within our portfolio.

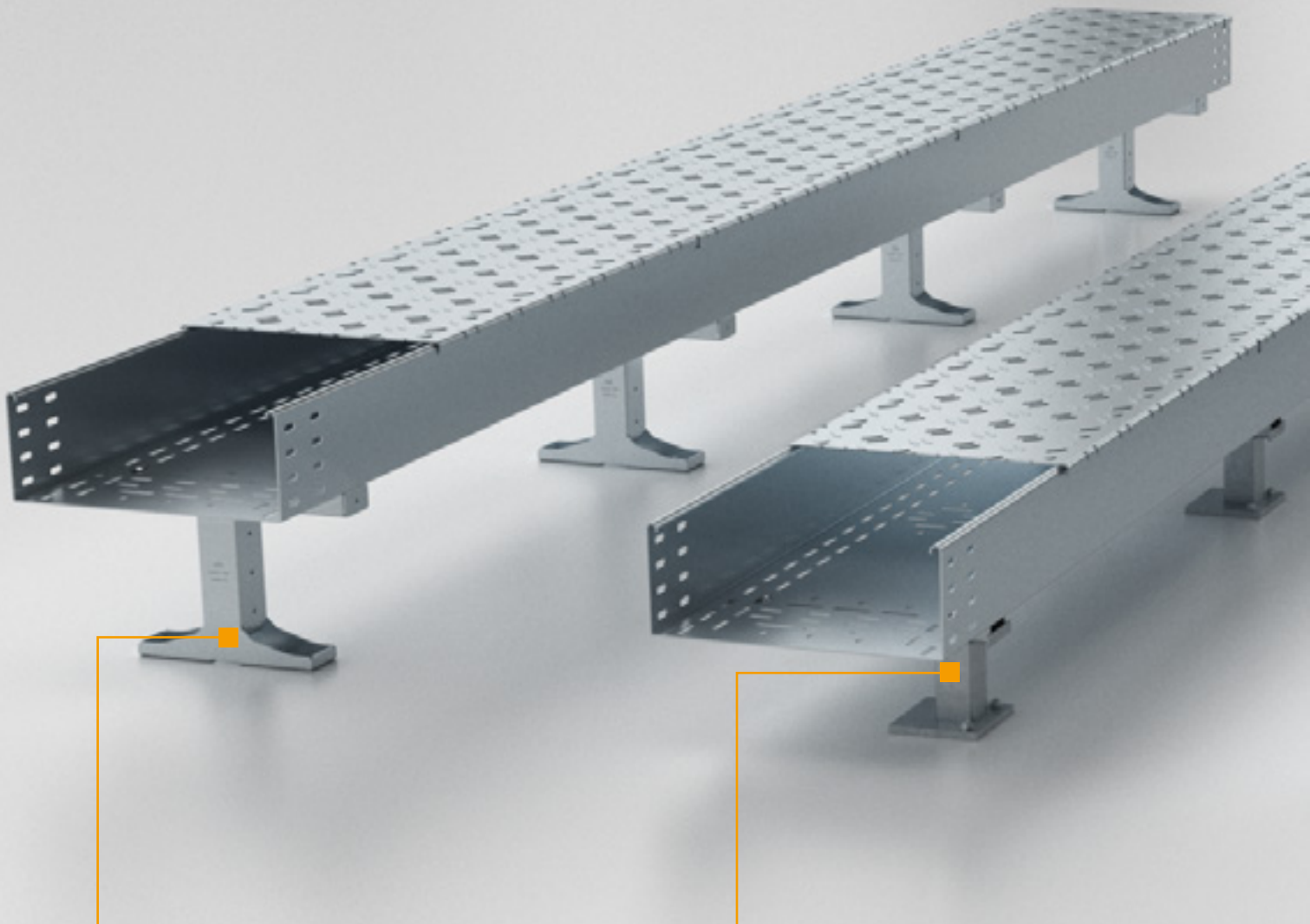

## Symmetrical support for Mercedes-Benz according to integra 7i

- Meets health and safety guidelines to avoid the risk of slipping/tripping
- Step height approx. 290–300 mm (depending on the system height)
- Space for routing under the system
- 2-part support enables faster, improved mounting
- Threaded glands enable simple mounting of the cable tray to the crossbeam and faster mounting of the pipe clips (from Rehau) on the base of the support

## Support bracket for VW AG according to VASS V6

- Step height approx. 200–210 mm (depending on the system height)
- Cable tray fastening via self-tapping screw
- Space for routing under the system

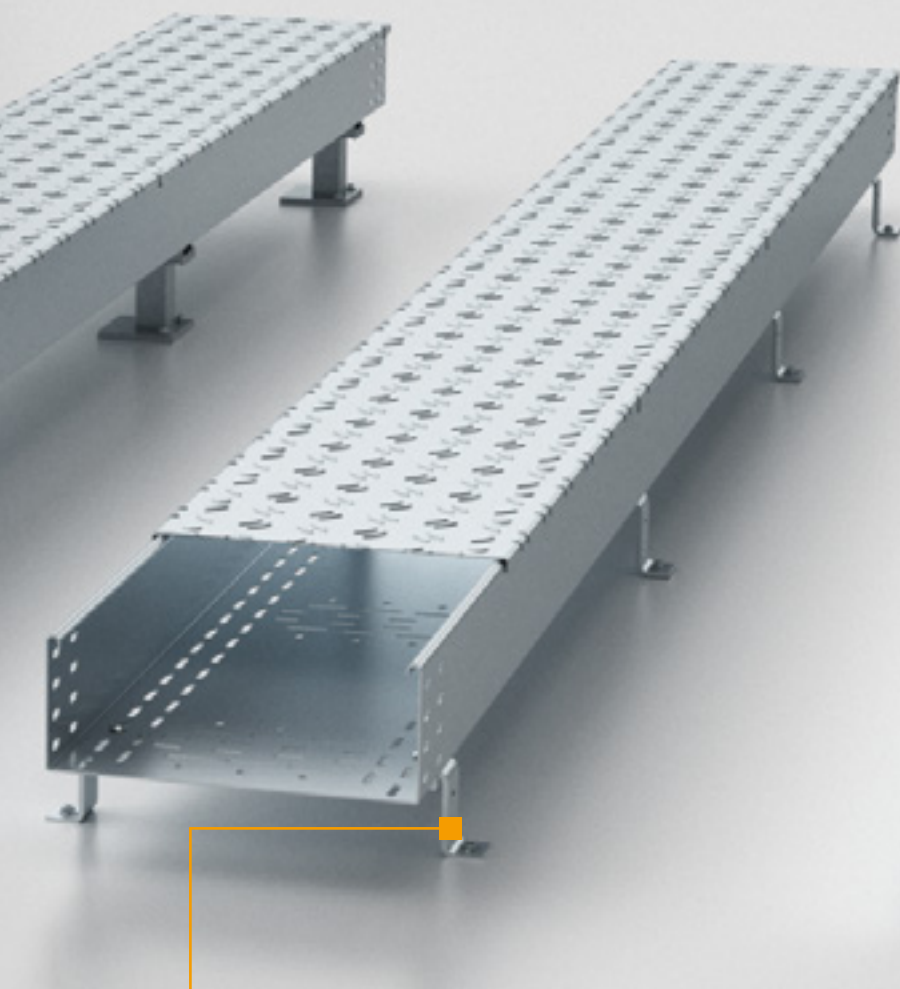

## Z support for BMW

- Max. system height 200 mm, fits under most protection fences
- Simple mounting of protective panels without additional drilling, thanks to prefabricated perforation in Z support and protective panel
- Space for routing under the system
- Prefabricated threaded hole for faster mounting of the cable tray on Z supports
- Together with the crossbeam, Z supports present a sturdy stand-off variant

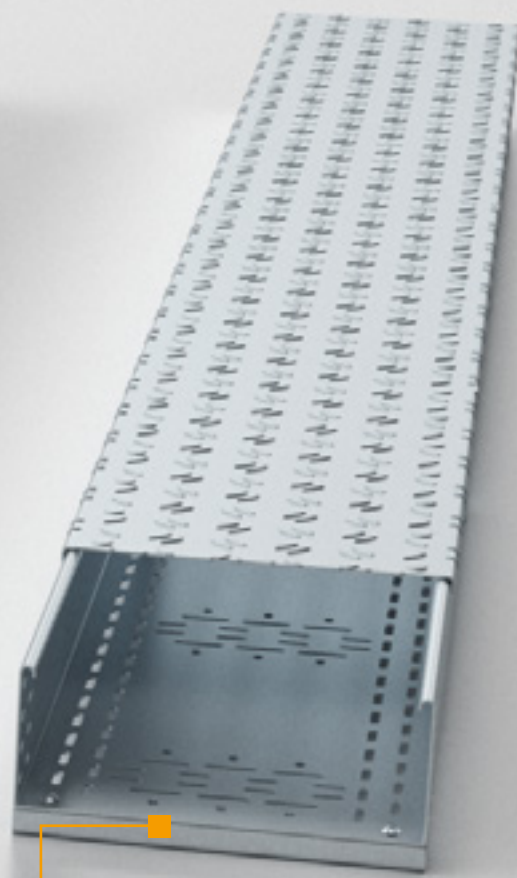

## Floor mounting on C rail

- Quick and easy mounting on the floor via C rail

# EMC protection and dust protection

All kinds of conditions are encountered in modern industrial plants. Often the environment is harsh, with dirt, vibrations and other side effects of industrial processes posing a serious risk to sensitive power, data and control cables. OBO's BKRS provides a safe, enclosed installation space for cables.

## EMC-tested

Through the use of a barrier strip, power, control and data cables are insulated according to DIN EN 50174, to ensure electromagnetic compatibility. The trays and covers themselves provide perfect all-round protection for the cables.

The image shows a close-up of a cable tray system. The tray is made of a light-colored material with a pattern of raised, oval-shaped elements. The cover is also made of a similar material and is shown partially open, revealing the tray underneath. The dust protection elements are small, oval-shaped pieces that fit into the gaps between the covers. An orange text box is overlaid on the right side of the image, containing the title 'Dust protection' and a paragraph of text. An inset image in the bottom right corner shows a different view of the cable tray system, highlighting the dust protection elements in a more detailed way.

## Dust protection

OBO is the only provider on the market to offer special dust protection elements for cover transitions. They are mounted between the cable tray and cover, meaning they do not impair the anti-slip properties of the BKRS cover. By closing the gap between two adjacent covers, they protect the inside of the cable trays reliably from foreign objects, such as dust and dirt. With variable settings, the protective elements are suitable for any application. Protection is extended even in metered covers (1–90°).

# End-to-end equipotential bonding

Earth Bonding Systems within the cable tray profile

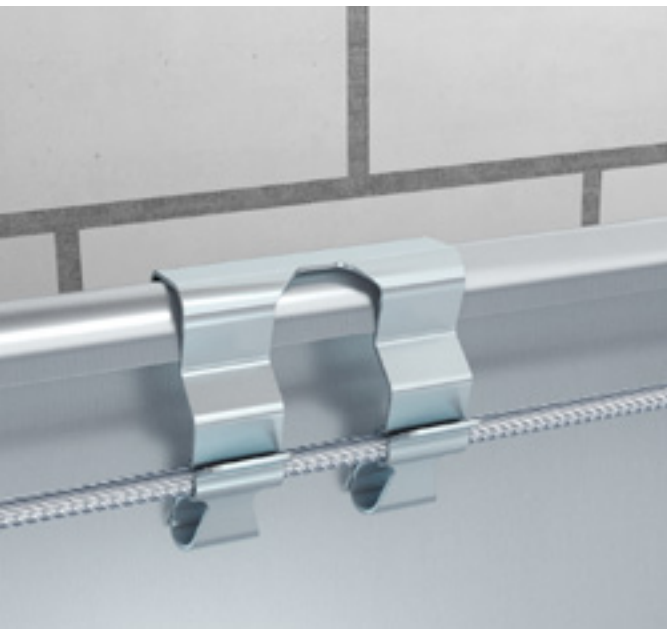

A continuous tin-plated copper cable can be guided directly in the cable tray profile and fixed using the clamp spring. Installation is easy, done without tools or drilling any additional holes. Its – ideal for quick and clean integration into existing OBO systems.

## Advantages at a glance:

- Direct routing of the copper cable in the cable tray (e.g. type 6061985)
- Clamp spring for toolless fastening without drilling on the cable tray (6049273)
- Use of tin-plated copper cables in accordance with DIN VDE 0295 Class 2, multi-wire and tin-plated copper cables in accordance with DIN VDE 0295 Class 5, fine-wire and pair-stranded
- For conductor cross sections of 16 mm<sup>2</sup> to 35 mm<sup>2</sup>
- Maximum terminal spacing: 1.5 m
- Quick contacting: Copper cable is inserted directly into the clamping spring

# Equipotential bonding

under the cable tray



In this system, the conductor cable is guided under the cable tray using connection terminals. Tin-plated copper cables in accordance with DIN VDE 0295 Class 2, multi-wire and tin-plated conductor cables according to DIN VDE 0295 Class 5, fine-wire and pair-stranded, from 16 mm<sup>2</sup> to 35 mm<sup>2</sup> can be used.

## Advantages at a glance:

- Fastening done using the connection terminal (6049275)
- Two exits of round conductors up to 35 mm<sup>2</sup> possible



# Equipotential bonding

with central exit

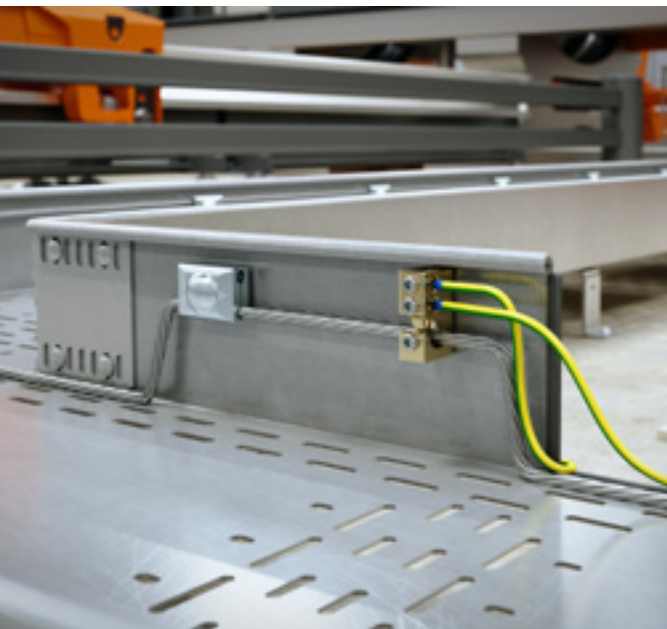

Equipotential bonding is achieved using a 35 mm<sup>2</sup> copper cable, routed continuously using parallel connectors. The connection terminal 6049275 can be mounted anywhere and connected to the conductor cable. It has 2 exits for round conductors up to 35 mm<sup>2</sup>.

## Advantages at a glance:

- Robust cable routing of 35 mm<sup>2</sup> tin-plated copper cables in accordance with DIN VDE 0295 Class 2, multi-wire with parallel connectors (5315700)
- Mounting of the terminal clamp anywhere on the conductor cable (6049275)
- Two exits of round conductors up to 35 mm<sup>2</sup> possible

# Equipotential bonding

with flexible branch structure

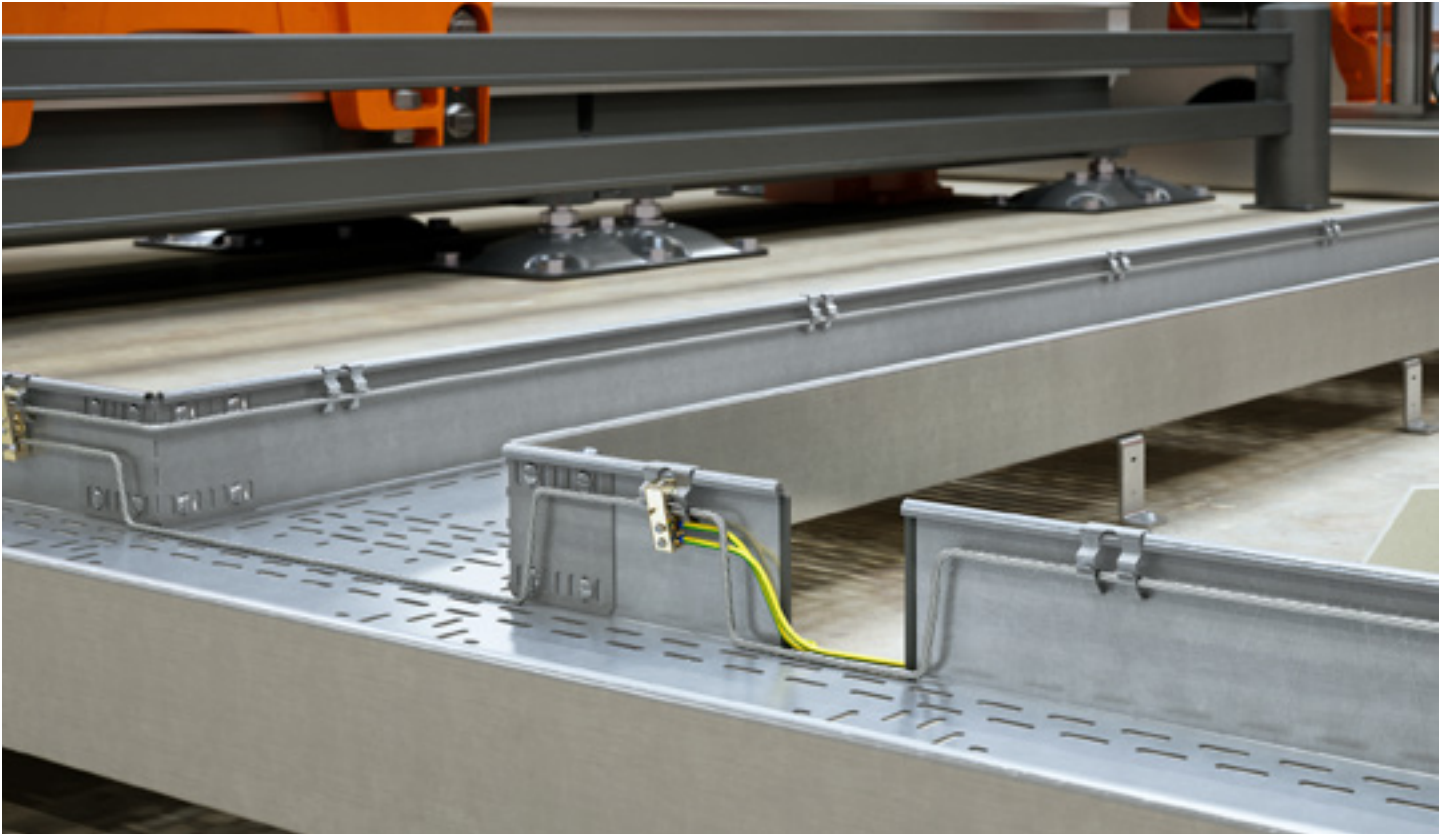

This system enables structured earthing with flexible branches. Copper cables are supported using special connection terminals and guided via round conductors. The ideal solution for branched earthing grids with different cable cross-sections.

## Advantages at a glance:

- Connection terminals for supporting one copper cable 16 mm<sup>2</sup> to 35 mm<sup>2</sup> (6049276 / 6049278)
- Two exits for round conductors (25 mm<sup>2</sup> / 35 mm<sup>2</sup>) possible
- Connection terminals for supporting two copper cables 16 mm<sup>2</sup> to 35 mm<sup>2</sup> for creating branches (e.g. type 6049277 / 6049279)
- Two exits for round conductors (25 mm<sup>2</sup> / 35 mm<sup>2</sup>) possible

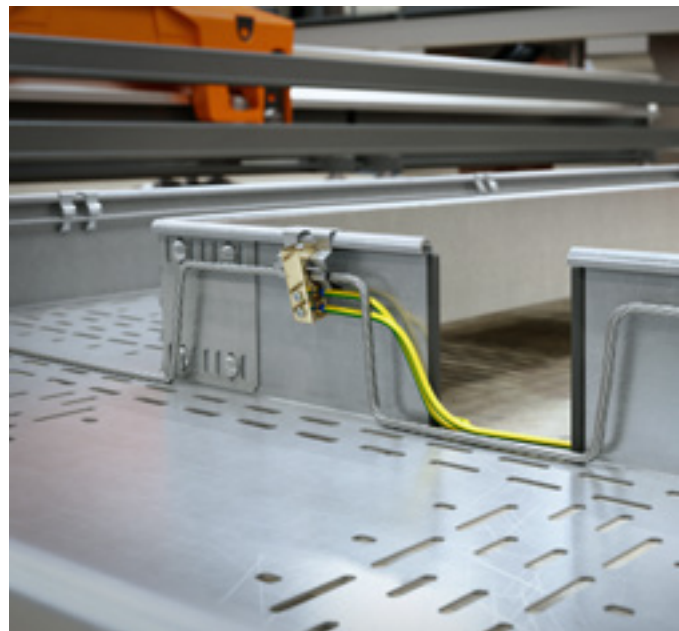

# Assembly options to meet every requirement

Comprehensive accessories for the BKRS cable tray offer a range of mounting benefits

The chequer plate cover not only offers ideal slip prevention, it can also be mounted with the BKRS cover clamp. As an alternative to the turn buckle, the cover clamp can be attached to the cover before mounting. The cover is then simply snapped onto the cable tray. Turnbuckles can also be used within the chequer plate cover. The cover is pre-prepared with turnbuckle knockouts every 100mm, this provides maximum flexibility when selecting the desired trunking/cover length.

With the matching cover lifter, the cover can be dismantled again just as easily. At the same time, the cover lifter can be used as a drilling template for connector perforations, for example to mount the RUVK universal connector. One connector for every direction – the RUVK universal connector can be used as both a straight and an angled connector. The optimised rounded inner edge of the connector reliably protects cables against damage during pulling. A cover support provides additional load support for the cover. If needed, it

also features rounded edges, which protect the cables during installation. The portfolio also includes protective panels and support brackets. The protective panel acts as a collision guard, protecting against mechanical impacts. With the support bracket the walkable cable tray system can be mounted.

## At a glance

- Cover clamps are an alternative to mounting with turn buckles
- Cover lifter is a dismantling tool with clever integrated drilling template for connection perforation
- Universal connector with integrated edge protection when creating horizontal exits
- Cover support for additional load bearing support
- Protective panel as a collision guard
- Various stand-off, support bracket solutions available.

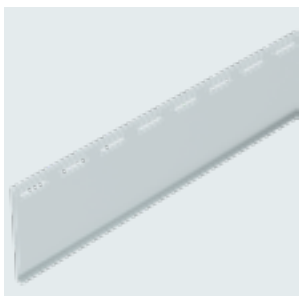

Protective panel



Cover support

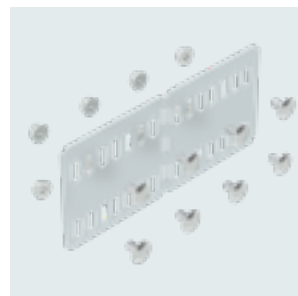

Universal connector



Cover lifter for chequer plate cover

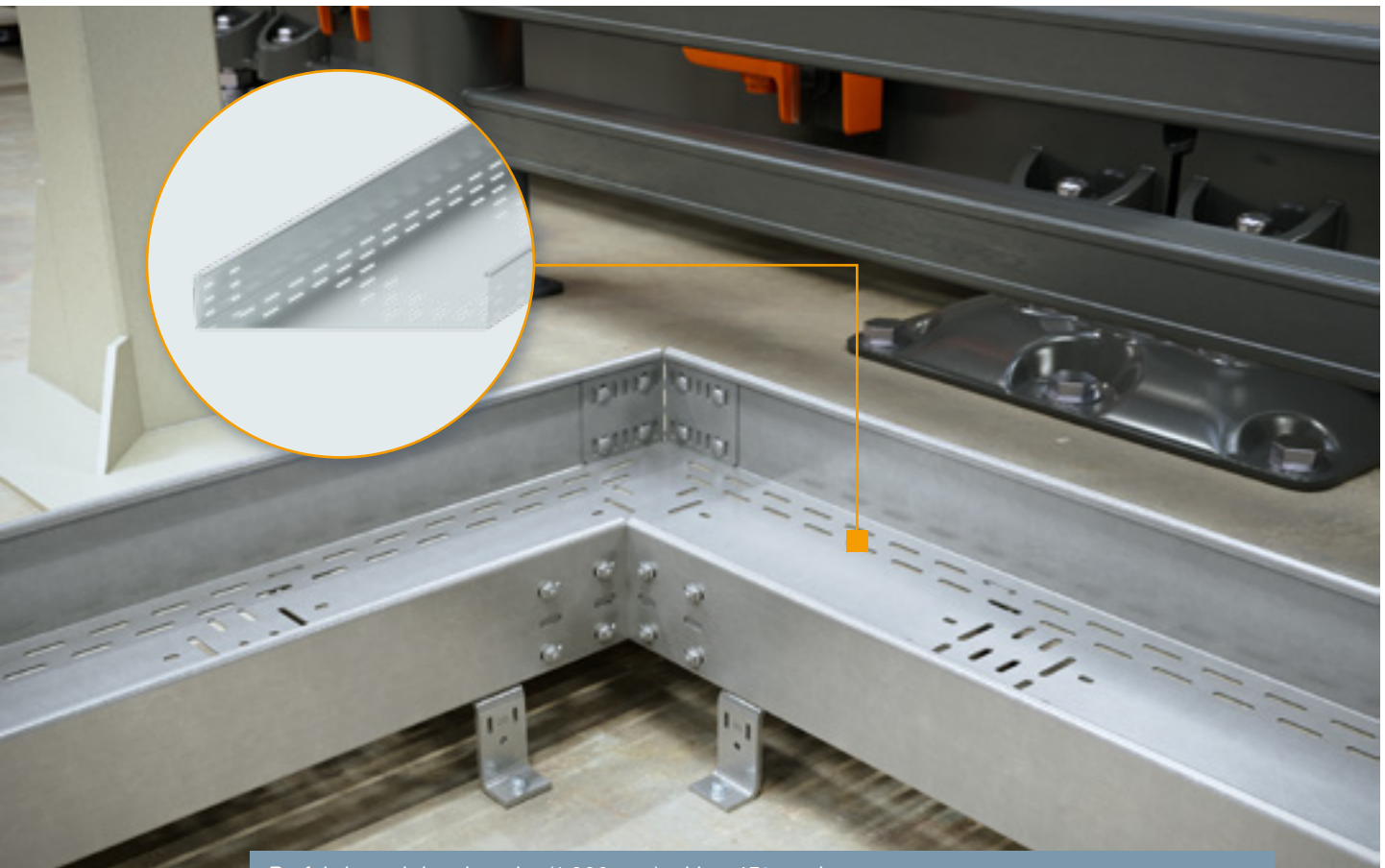

*Prefabricated duct lengths (1,000 mm) with a 45° angle*



*Walkable cable cover to protect cables on the ground.*

# Always there for you, across the globe

## Our international presence

At OBO, regional connections meet a global presence. With 7 production companies, 40 subsidiaries and almost 20 other agents, we are represented in over 60 countries across all continents. This makes us one of the most important players in the global electrical engineering market. The values of our company are supported by continuous proximity to our customers. For us, customer proximity means that whenever borders open and new markets are created, we will be there.

## Our solutions – tailored just for you

Each automotive manufacturer places different requirements on the systems they use in their production environment. This includes individual needs, mounting environments and installation requirements. We at OBO know that thanks to our experience from countless projects worldwide. This is why we offer a custom product brochure and custom mounting instructions for each automotive manufacturer. This is unique on the market, but goes without saying for us. Because tailoring our approach to each of our customers is standard for us.



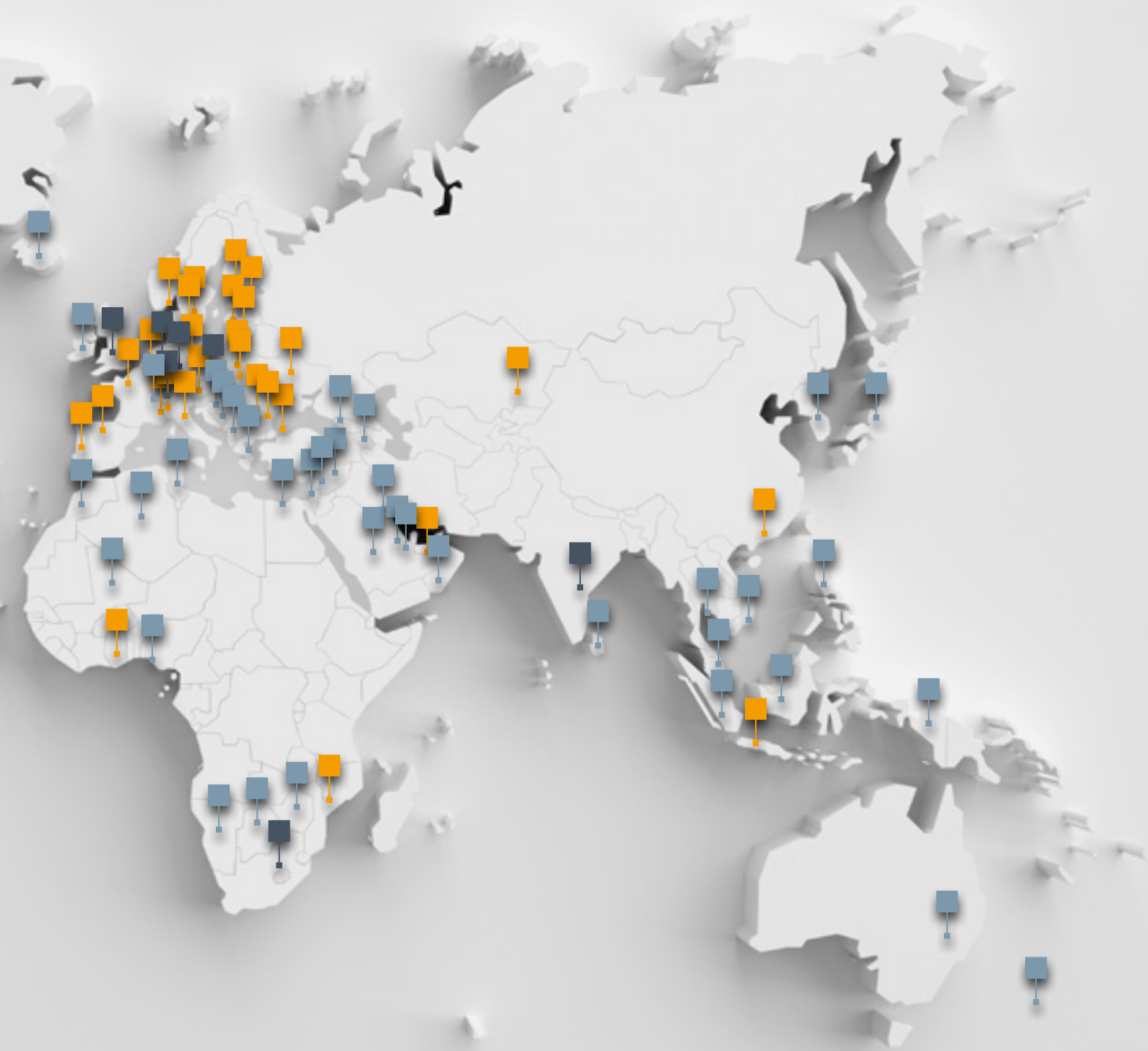

- Subsidiaries
- Production locations
- Agencies

## Cable tray MKS 60

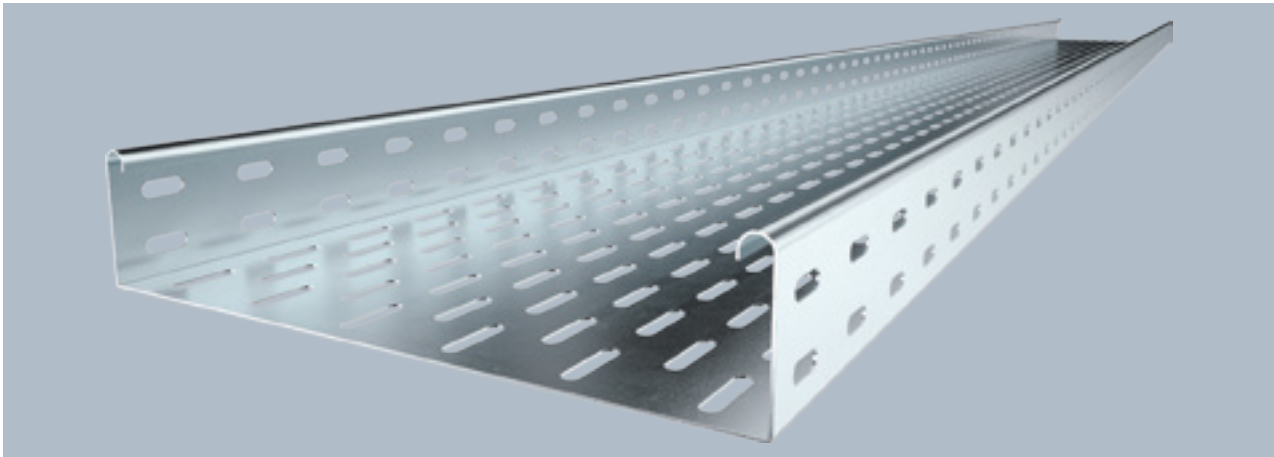

Type	Width mm	Metal thick- ness mm	Min. order- ing quan- tity m	Item no.
<b>MKS 610 FS</b>	100	1.00	3	<b>6055109</b>
<b>MKS 620 FS</b>	200	1.00	3	<b>6055206</b>
<b>MKS 630 FS</b>	300	1.00	3	<b>6055303</b>

MKS 60 = medium-duty cable tray system with a side height of 60 mm.

Type	Length mm	Dimension W mm	Usable cross- section cm <sup>2</sup>
<b>MKS 610 FS</b>	3000	100	58
<b>MKS 620 FS</b>	3000	200	118
<b>MKS 630 FS</b>	3000	300	178

### Dimensions

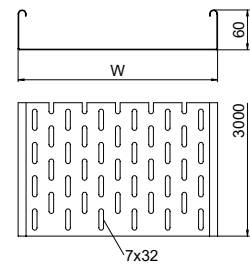

St FS

Cable tray SKS 60

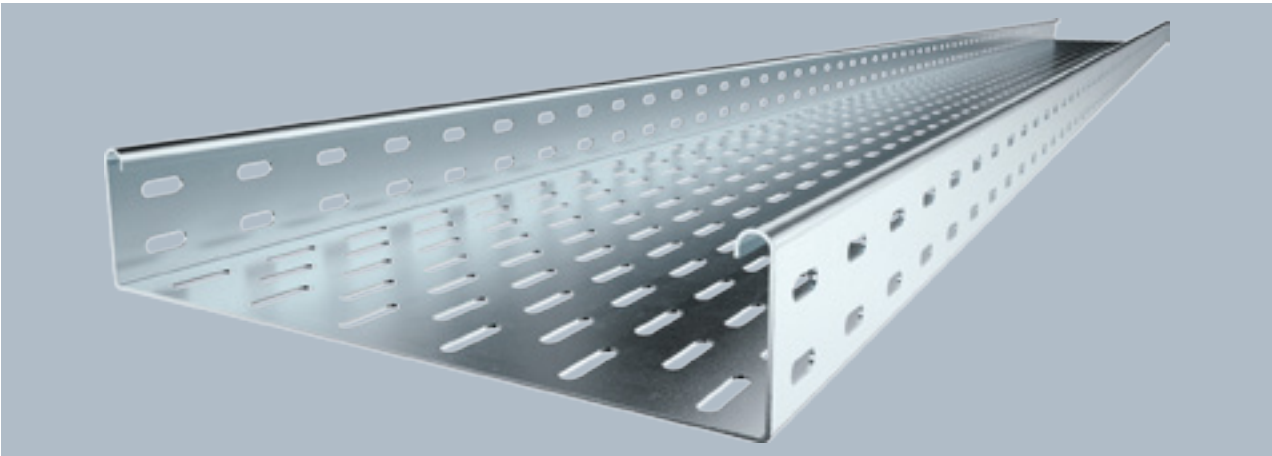

SKS 60 = heavy-duty cable tray system with 60 mm side height.

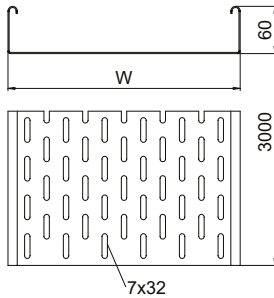

Type	Width mm	Metal thickness mm	BS	Min. ordering quantity m	Item no.
SKS 610 FS	100	1.50		3	6056105
SKS 620 FS	200	1.50		3	6056202
SKS 630 FS	300	1.50		3	6056296

St FS



Cable tray for conveyor technology

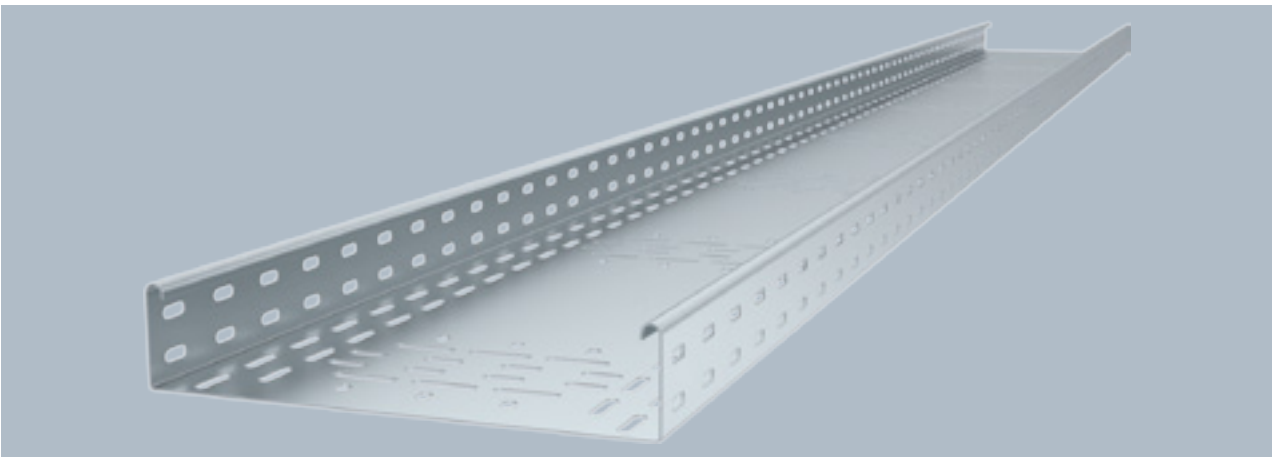

Perforated cable tray for the routing of cables, especially suited for material handling technology in the automotive industry. Can be used in indoor areas. Screw connection. Suitable for direct and elevated floor mounting.

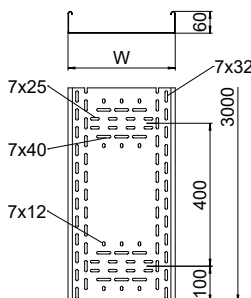

Type	Side height mm	Dim. H mm	Dim. B mm	Dim. L mm	Metal thickness mm	Min. ordering quantity m	Item no.
BKRS F 610 FS	60	60	100	3000	1.50	3	6061841
BKRS F 620 FS	60	60	200	3000	1.50	3	6061843
BKRS F 630 FS	60	60	300	3000	1.50	3	6061845

## Straight connector 60

St FS

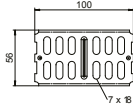

Type	Side height mm	Min. ordering quantity Piece	Item no.
RLVK 60 FS	60	10	6067093

Straight connector for straight connection of cable trays and fittings with a side height of 60 mm. Including appropriate fastening material.

## Adjustable connector 60

St FS

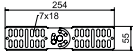

Type	Side height mm	Min. ordering quantity Piece	Item no.
RGV 60 FS	60	10	7082010

Adjustable connector for cable trays with a side height of 60 mm. Including appropriate fastening material.

## Straight and angle connector 60

St FS

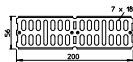

Type	Side height mm	Min. ordering quantity Piece	Item no.
RWVL 60 FS	60	10	6067115

Straight and angle connector for cable trays and fittings with a side height of 60 mm. Including appropriate fastening material.

## Barrier strip 60

St FS

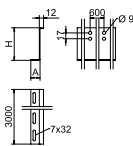

Type	Dim. H mm	Metal thickness mm	Length mm	Min. ordering quantity m	Item no.
TSG 60Z BKRS FS	55	1.50	3000	3	6062389

Barrier strip for the BKRS walkable cable tray system. Fastening with truss-head bolts M 6 x 12 in the base perforation.

For widths of 200 mm or more, a barrier strip with a maximum compartment size of 220 mm should be used. For widths of 500 mm or more, two barrier strips with a maximum compartment size of 220 mm should be used.

## Separating retainer 60

St FS

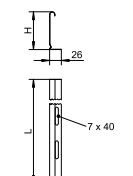

Type	Dim. H mm	Metal thickness mm	Dim. L mm	Min. ordering quantity m	Item no.
TSG 60 FS	60	0.75	3000	3	6062068

Separating retainer for separation of cables of different voltages or functions.

St G

Truss-head bolt with combination nut

Type	Dimen- sion mm	Dim. L mm	Dim. d mm	Dim. D mm	Resist- ance grade	Resist- ance grade	Min. order- ing quan- tity Piece	Item no.
<b>FRSB 6x12 G</b>	M6x12	12	6	13,5	5,6		100	<b>6406130</b>

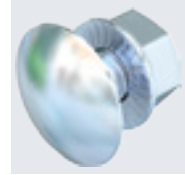
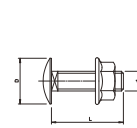

Hot galvanised truss-head bolt with square neck including electrogalvanised combination nut.  
For universal fastening of construction components. Permitted use of the article only in dry atmospheres.

St FS

Reducer/stop-end 60

Type	Side height mm	Dim. B mm	Min. order- ing quan- tity Piece	Item no.
<b>RWEB 610 FS</b>	60	100	1	<b>7109105</b>
<b>RWEB 620 FS</b>	60	200	1	<b>7109202</b>
<b>RWEB 630 FS</b>	60	300	1	<b>7109296</b>

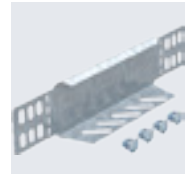
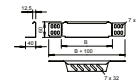

Reducer/stop-end plate for cable trays with side height 60 mm.  
From a width of 150 mm, a perforated lower flange is available.  
Including appropriate fastening material.

## Cable tray MKS 85

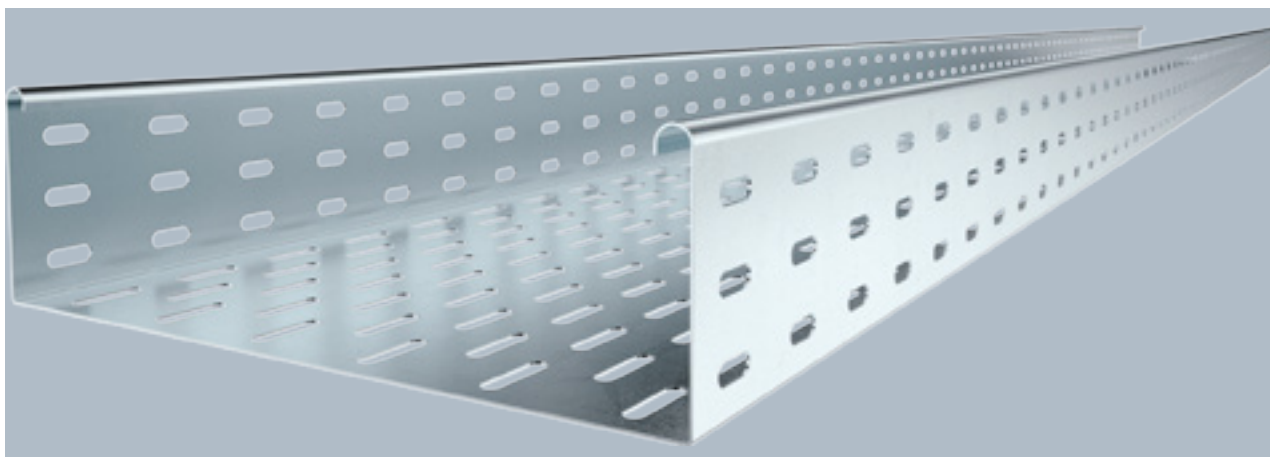

Type	Width mm	Metal thickness mm	Length mm	Dimension W mm	Usable cross-section cm <sup>2</sup>	Pack m	Item no.
<b>MKS 810 FS</b>	100	1.00	3000	100	83	3	<b>6057101</b>
<b>MKS 820 FS</b>	200	1.00	3000	200	186	3	<b>6057209</b>
<b>MKS 830 FS</b>	300	1.00	3000	300	253	3	<b>6057306</b>

MKS 85 = medium-duty cable tray system with a side height of 85 mm.

Magnetic shield insulation without cover 20 dB, with cover 50 dB.

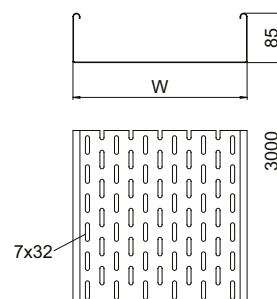

## Cable tray SKS 85

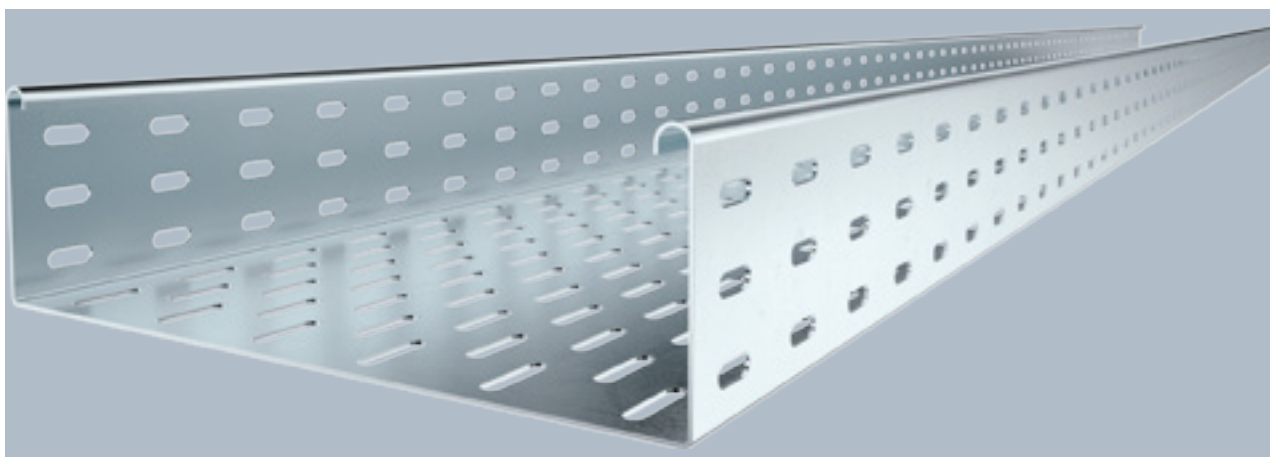

Type	Width mm	Metal thickness mm	Length mm	Dimension W mm	Usable cross-section cm <sup>2</sup>	Pack m	Item no.
<b>SKS 810 FS</b>	100	1.50	3000	100	83	3	<b>6058108</b>
<b>SKS 820 FS</b>	200	1.50	3000	200	186	3	<b>6058205</b>
<b>SKS 830 FS</b>	300	1.50	3000	300	253	3	<b>6058302</b>

SKS 85 = heavy-duty cable tray system with 85 mm side height.

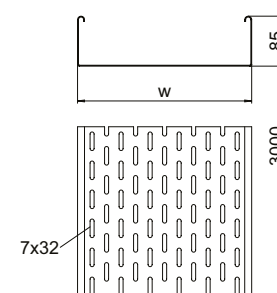

St FS



## Cable tray for conveyor technology

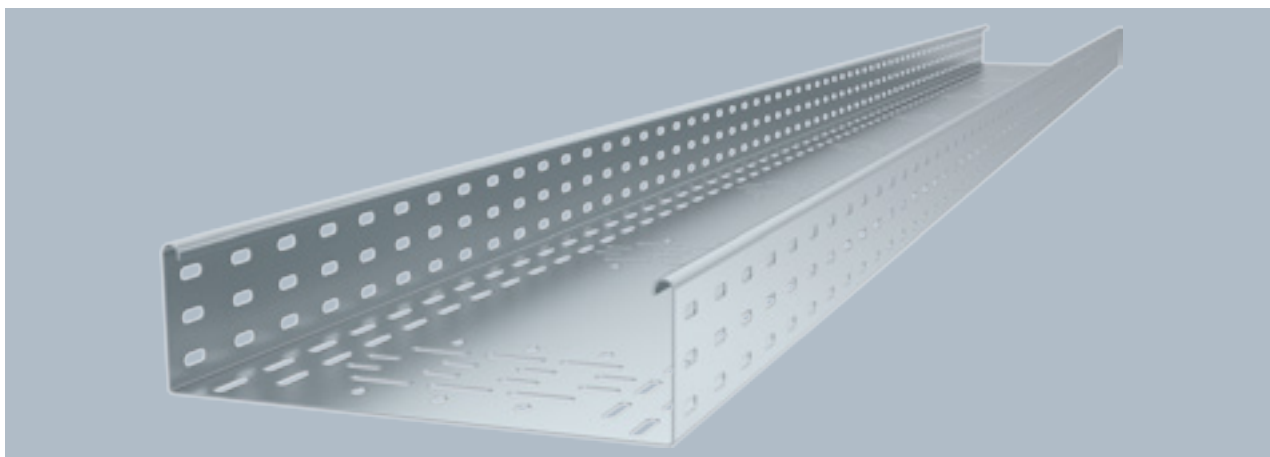

Perforated cable tray for the routing of cables, especially suited for material handling technology in the automotive industry. Can be used in indoor areas. Screw connection. Suitable for direct and elevated floor mounting.

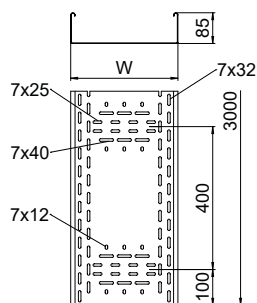

Type	Side height mm	Dim. H mm	Dim. B mm	Dim. L mm	Metal thickness mm	Min. ordering quantity m	Item no.
BKRS F 810 FS	85	85	100	3000	1.50	3	6061851
BKRS F 820 FS	85	85	200	3000	1.50	3	6061853
BKRS F 830 FS	85	85	300	3000	1.50	3	6061855

## Straight and angle connector 85

St FS

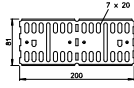
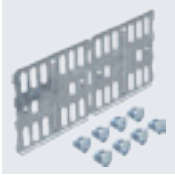

Type	Side height mm	Min. ordering quantity Piece	Item no.
<b>RLVL 85 FS</b>	85	10	<b>6067123</b>

Straight and angle connector for cable trays and fittings with a side height of 85 mm. Including appropriate fastening material.

## Adjustable connector 85

St FS

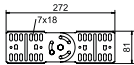

Type	Side height mm	Min. ordering quantity Piece	Item no.
<b>RGV 85 FS</b>	85	10	<b>7082029</b>

Adjustable connector for cable trays with a side height of 85 mm. Including appropriate fastening material.

## Barrier strip 85

St FS

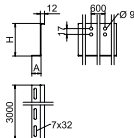

Type	Side height mm	Metal thickness mm	Length mm	Min. ordering quantity m	Item no.
<b>TSG 85Z BKRS FS</b>	85	1.50	3000	3	<b>6062388</b>

Barrier strip for the BKRS walkable cable tray system. Fastening with truss-head bolts M 6 x 12 in the base perforation.

For widths of 200 mm or more, a barrier strip with a maximum compartment size of 220 mm should be used. For widths of 500 mm or more, two barrier strips with a maximum compartment size of 220 mm should be used.

## Separating retainer 85

St FS

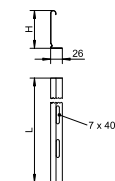

Type	Dim. H mm	Metal thickness mm	Dim. L mm	Dim. quantity	Min. ordering quantity m	Item no.
<b>TSG 85 FS</b>	85	0.75	3000	3		<b>6062114</b>

Separating retainer for separation of cables of different voltages or functions.

## Truss-head bolt with combination nut

St G

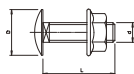

Type	Dimen- sion mm	Dim. L mm	Dim. d mm	Dim. D mm	Resist- ance grade	Min. ordering quantity Piece	Item no.
<b>FRSB 6x12 G</b>	M6x12	12	6	13.5	5.6	100	<b>6406130</b>

Hot galvanised truss-head bolt with square neck including electrogalvanised combination nut. For universal fastening of construction components. Permitted use of the article only in dry atmospheres.

St FS

## Reducer/stop-end 85

Type	Side height mm	Dim. B mm	Min. ordering quantity Piece	Item no.
<b>RWEB 810 FS</b>	85	100	1	<b>7110103</b>
<b>RWEB 820 FS</b>	85	200	1	<b>7110200</b>
<b>RWEB 830 FS</b>	85	300	1	<b>7110308</b>

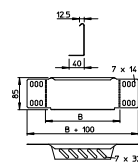

Reducer/stop-end for cable trays with side height 85 mm.

From a width of 150 mm, a perforated bottom flange is available.  
Including appropriate fastening material.

### Unperforated cover

St FS

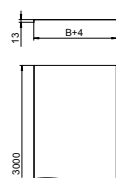
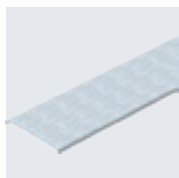

Type	Dim. B mm	Metal thickness mm	Length mm	Min. ordering quantity m	Item no.
<b>DRLU 100 FS</b>	100	1.00	3000	3	6052103
<b>DRLU 200 FS</b>	200	1.00	3000	3	6052210
<b>DRLU 300 FS</b>	300	1.00	3000	3	6052307

Cover for cable trays and mesh cable trays.  
When using covers outdoors, additional measures against the influence of wind must be taken.  
Transverse bead from 500 mm width.

### Cover with turn buckle

St FS

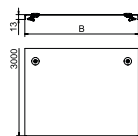

Type	Dim. B mm	Metal thickness mm	Length mm	Min. ordering quantity m	Item no.
<b>DRL 100 FS</b>	100	1.00	3000	3	6052096
<b>DRL 200 FS</b>	200	1.00	3000	3	6052207
<b>DRL 300 FS</b>	300	1.00	3000	3	6052304

Transverse bead from 500 mm width.  
Cover for cable trays and cable ladders with turn buckles.  
When using covers outdoors, additional measures against the influence of wind must be taken.

### Cover clamp

A2 2B



Type	Min. ordering quantity Piece	Item no.
<b>DK DRLU A2</b>	30	6052810

Cover clamp for secure fastening of covers on cable trays and cable ladders.  
At least 6 cover clamps should be mounted for each 3 metres of cover.

### Wall and support bracket, angle head

St FT

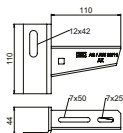

Type	Min. ordering quantity Piece	Item no.
<b>AW 30 11 WK FT</b>	1	6419855
<b>AW 30 21 WK FT</b>	1	6419856
<b>AW 30 31 WK FT</b>	1	6419857

Heavy-duty wall and support bracket with welded angle head plate, for fastening to walls or structures.

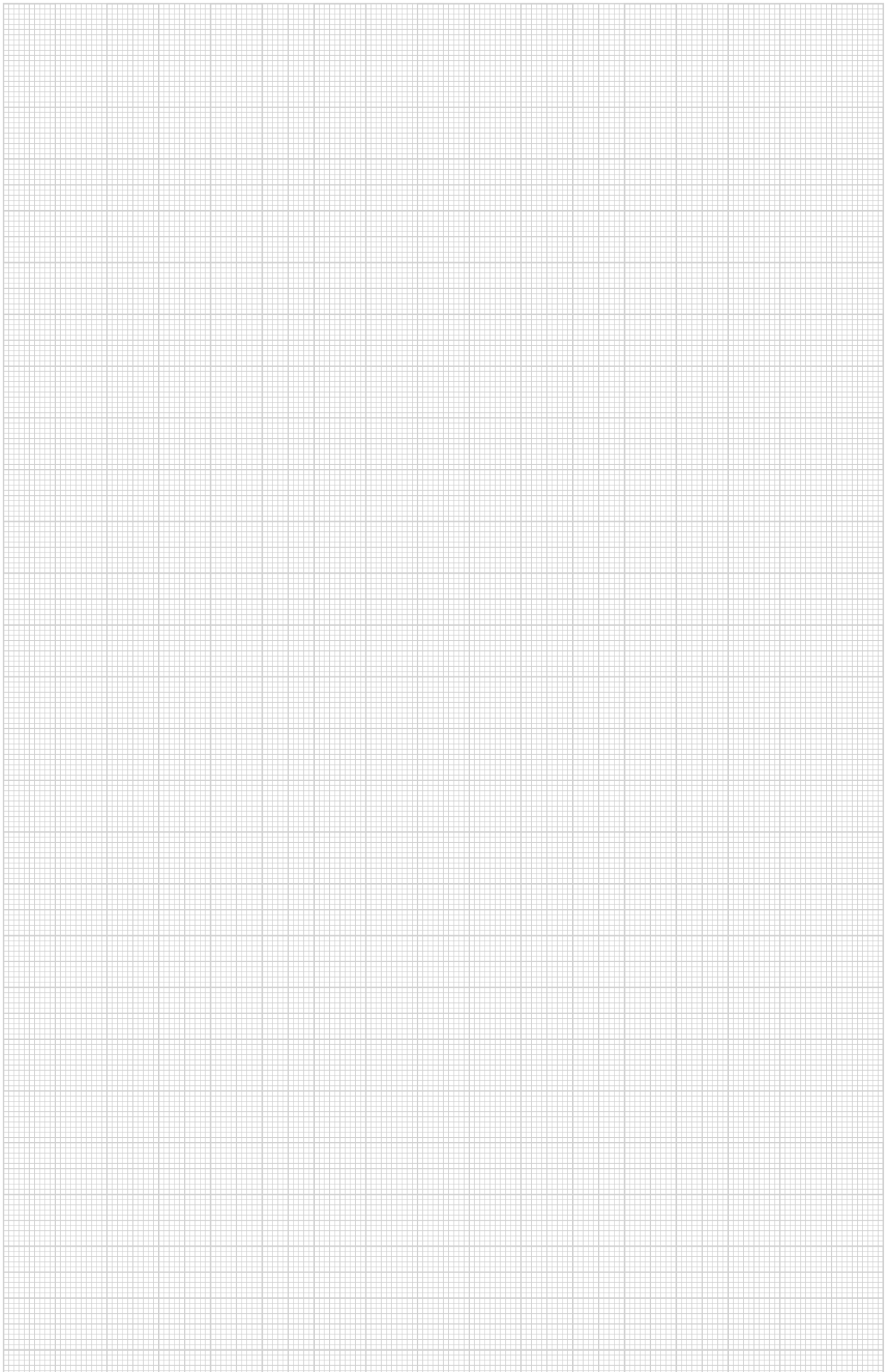

## Cable tray BKRS 100



Type	Side height mm	Dim. H mm	Dim. B mm	Dim. L mm	Metal thickness mm	Min. ordering quantity m	Item no.
<b>BKRS 1010 FS</b>	100	100	100	3000	2.00	3	<b>6062000</b>
<b>BKRS 1020 FS</b>	100	100	200	3000	2.00	3	<b>6062002</b>
<b>BKRS 1030 FS</b>	100	100	300	3000	2.00	3	<b>6062004</b>
<b>BKRS 1040 FS</b>	100	100	400	3000	2.00	3	<b>6062006</b>
<b>BKRS 1050 FS</b>	100	100	500	3000	2.00	3	<b>6062008</b>
<b>BKRS 1060 FS</b>	100	100	600	3000	2.00	3	<b>6062010</b>

Heavy-duty, walkable cable tray system BKRS with base perforation, in 100 mm side height.

The cable tray has connector perforations on both sides. Straight connectors should be ordered separately and in the appropriate quantity.

Magnetic shield insulation without cover 20 dB, with cover 50 dB.

Type	Dim. L mm	Dim. B mm	Dim. H mm	Metal thickness mm	Usable cross-section cm <sup>2</sup>
BKRS 1010 FS	3000	100	100	2.00	84
BKRS 1020 FS	3000	200	100	2.00	171
BKRS 1030 FS	3000	300	100	2.00	258
BKRS 1040 FS	3000	400	100	2.00	345
BKRS 1050 FS	3000	500	100	2.00	432
BKRS 1060 FS	3000	600	100	2.00	519

### Dimensions

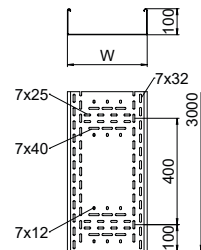

St FS



BKRS 100 cable tray, shortened

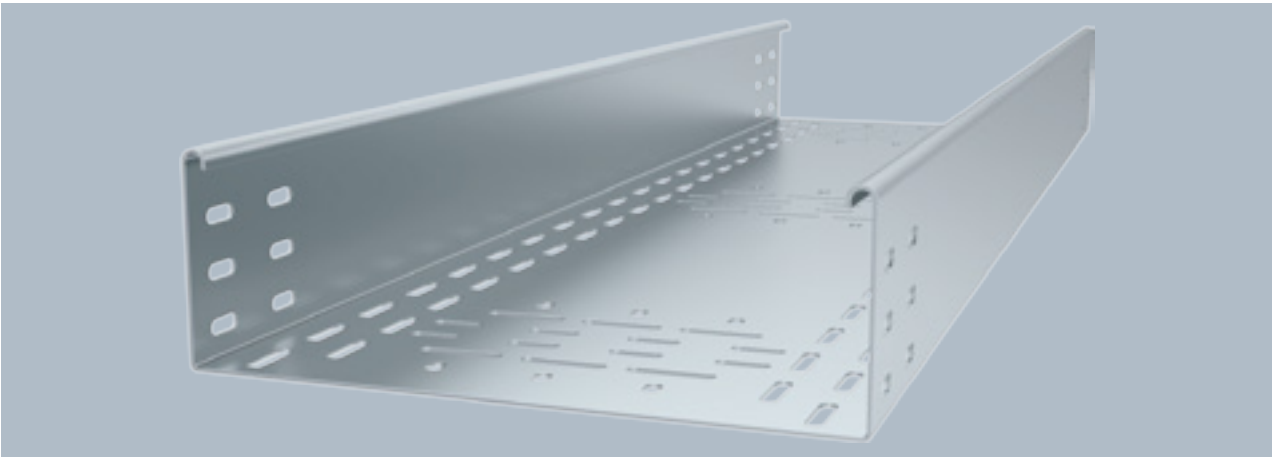

Cable tray fitting with shortened length, for creation the of straight sections on walkable cable trays.

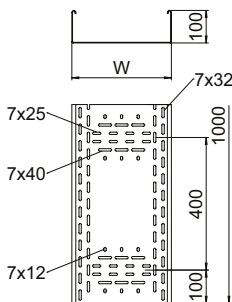

Type	Side height mm	Dim. H mm	Dim. B mm	Dim. L mm	Metal thickness mm	Min. ordering quantity Piece	Item no.
BKRS 1010 10 FS	100	100	100	1000	2.00	1	6061895
BKRS 1020 10 FS	100	100	200	1000	2.00	1	6061896
BKRS 1030 10 FS	100	100	300	1000	2.00	1	6061897
BKRS 1040 10 FS	100	100	400	1000	2.00	1	6061898
BKRS 1050 10 FS	100	100	500	1000	2.00	1	6061899
BKRS 1060 10 FS	100	100	600	1000	2.00	1	6061900

St FS



BKRS 100 cable tray, shortened

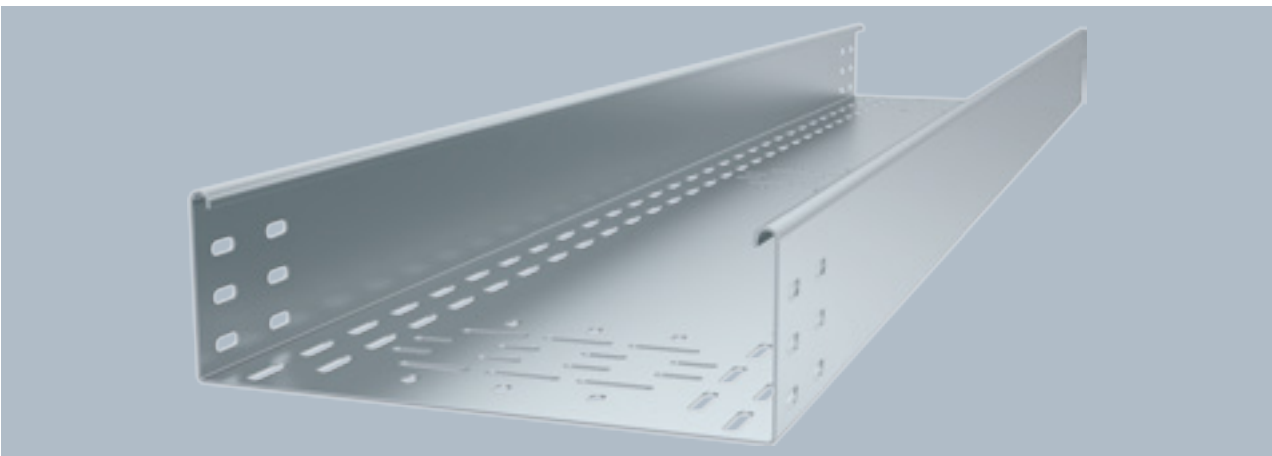

Cable tray fitting with shortened length, for creation the of straight sections on walkable cable trays.

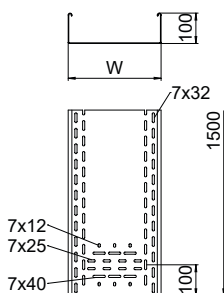

Type	Side height mm	Dim. H mm	Dim. B mm	Dim. L mm	Metal thickness mm	Min. ordering quantity Piece	Item no.
BKRS 1010 15 FS	100	100	100	1500	2.00	1	6061970
BKRS 1020 15 FS	100	100	200	1500	2.00	1	6061972
BKRS 1030 15 FS	100	100	300	1500	2.00	1	6061974
BKRS 1040 15 FS	100	100	400	1500	2.00	1	6061976
BKRS 1050 15 FS	100	100	500	1500	2.00	1	6061978
BKRS 1060 15 FS	100	100	600	1500	2.00	1	6061980

## 45° fitting, left, BKRS 100

St FS

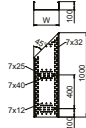

Type	Dim. H mm	Dim. B mm	Dim. L mm	Metal thickness mm	Min. ordering quantity Piece	Item no.
<b>BKRS 1010 45L FS</b>	100	100	1000	2.00	1	<b>6061911</b>
<b>BKRS 1020 45L FS</b>	100	200	1000	2.00	1	<b>6061912</b>
<b>BKRS 1030 45L FS</b>	100	300	1000	2.00	1	<b>6061913</b>
<b>BKRS 1040 45L FS</b>	100	400	1000	2.00	1	<b>6061914</b>
<b>BKRS 1050 45L FS</b>	100	500	1000	2.00	1	<b>6061916</b>
<b>BKRS 1060 45L FS</b>	100	600	1000	2.00	1	<b>6061917</b>

Cable tray fitting with 45° cut, for creation of bends on walkable cable trays.

## 45° fitting, right, BKRS 100

St FS

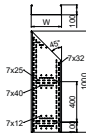

Type	Dim. H mm	Dim. B mm	Dim. L mm	Metal thickness mm	Min. ordering quantity Piece	Item no.
<b>BKRS 1010 45R FS</b>	100	100	1000	2.00	1	<b>6061903</b>
<b>BKRS 1020 45R FS</b>	100	200	1000	2.00	1	<b>6061904</b>
<b>BKRS 1030 45R FS</b>	100	300	1000	2.00	1	<b>6061905</b>
<b>BKRS 1040 45R FS</b>	100	400	1000	2.00	1	<b>6061906</b>
<b>BKRS 1050 45R FS</b>	100	500	1000	2.00	1	<b>6061908</b>
<b>BKRS 1060 45R FS</b>	100	600	1000	2.00	1	<b>6061909</b>

Cable tray fitting with 45° cut, for creation of bends on walkable cable trays.

## BKRS fitting, left notching, 100

St FS

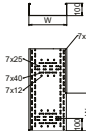

Type	Dim. H mm	Dim. B mm	Dim. L mm	Metal thickness mm	Min. ordering quantity Piece	Item no.
<b>BKRS 1010 90L FS</b>	100	100	1000	2.00	1	<b>6061918</b>
<b>BKRS 1020 90L FS</b>	100	200	1000	2.00	1	<b>6061920</b>
<b>BKRS 1030 90L FS</b>	100	300	1000	2.00	1	<b>6061922</b>
<b>BKRS 1040 90L FS</b>	100	400	1000	2.00	1	<b>6061924</b>
<b>BKRS 1050 90L FS</b>	100	500	1000	2.00	1	<b>6061926</b>
<b>BKRS 1060 90L FS</b>	100	600	1000	2.00	1	<b>6061928</b>

Fitting with side notching for walkable cable tray systems to create 90° bends.

## BKRS fitting, right notching, 100

St FS

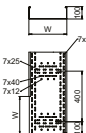
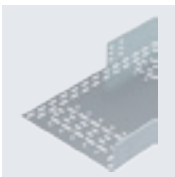

Type	Dim. H mm	Dim. B mm	Dim. L mm	Metal thickness mm	Min. ordering quantity Piece	Item no.
<b>BKRS 1010 90R FS</b>	100	100	1000	2.00	1	<b>6061930</b>
<b>BKRS 1020 90R FS</b>	100	200	1000	2.00	1	<b>6061932</b>
<b>BKRS 1030 90R FS</b>	100	300	1000	2.00	1	<b>6061934</b>
<b>BKRS 1040 90R FS</b>	100	400	1000	2.00	1	<b>6061936</b>
<b>BKRS 1050 90R FS</b>	100	500	1000	2.00	1	<b>6061938</b>
<b>BKRS 1060 90R FS</b>	100	600	1000	2.00	1	<b>6061940</b>

Fitting with side notching for walkable cable tray systems to create 90° bends.

St FS



Add-on tee BKRS

Type	Side height mm	Dim. B mm	Min. ordering quantity Piece	Item no.
RAA BKRS 1020 FS	100	200	1	6044622
RAA BKRS 1030 FS	100	300	1	6044623
RAA BKRS 1040 FS	100	400	1	6044624
RAA BKRS 1050 FS	100	500	1	6044625
RAA BKRS 1060 FS	100	600	1	6044626

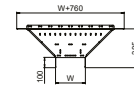

Add-on tee for a horizontal branch, fitting for BKRS walkable cable tray system. Suitable for mounting in indoor areas. With integrated connector. Fastening material must be ordered separately.

St FS



Cover for add-on tee, BKRS

Type	Dim. B mm	Metal thickness mm	Min. ordering quantity Piece	Item no.
DFAA BKRS 200 FS	200	2.00	1	6049421
DFAA BKRS 300 FS	300	2.00	1	6049423
DFAA BKRS 400 FS	400	2.00	1	6049425
DFAA BKRS 500 FS	500	2.00	1	6049427
DFAA BKRS 600 FS	600	2.00	1	6049429

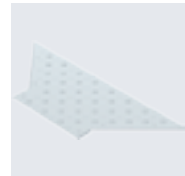
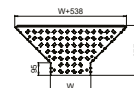

Unperforated cover with chequer plate for add-on tee fitting for BKRS walkable cable tray system. Suitable for mounting in indoor areas. To protect the cables against damage and soiling. With pre-marked break-out openings for fastening with turn buckles. Turn buckles not contained in scope of supply.

### Universal connector 100 FS

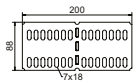

Type	Side height mm	Min. ordering quantity Piece	Item no.
<b>RUVK 100 FS</b>	100	10	<b>6067870</b>

Universal connector for horizontal straight and angle connections of walkable cable trays. In an angled state, with additional cable protection through flattened edges. Including fastening material.

### Barrier strip, Z-shaped 100

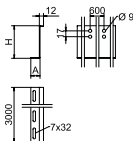

Type	Dim. H mm	Metal thickness mm	Length mm	Min. ordering quantity m	Item no.
<b>TSG100Z BKRS FS</b>	100	2.00	3000	3	<b>6062390</b>

Barrier strip for the BKRS walkable cable tray system. Fastening with truss-head bolts M6 x 12 in the base perforation.

For widths of 200 mm or more, a barrier strip with a maximum compartment size of 220 mm should be used. For widths of 500 mm or more, two barrier strips with a maximum compartment size of 220 mm should be used.

### Truss-head bolt with combination nut

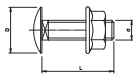

Type	Dimen- sion mm	Dim. L mm	Dim. d mm	Dim. D mm	Resist- ance grade	Min. ordering quantity Piece	Item no.
<b>FRSB 6x12 G</b>	M6x12	12	6	13.5	5.6	100	<b>6406130</b>

Hot galvanised truss-head bolt with square neck including electrogalvanised combination nut.

For universal fastening of construction components. Permitted use of the article only in dry atmospheres.

### Reducer/stop-end 100

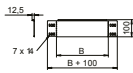

Type	Side height mm	Dim. B mm	Min. ordering quantity Piece	Item no.
<b>RWEB 1010 FS</b>	100	100	1	<b>7111802</b>
<b>RWEB 1020 FS</b>	100	200	1	<b>7111804</b>
<b>RWEB 1030 FS</b>	100	300	1	<b>7111806</b>
<b>RWEB 1040 FS</b>	100	400	1	<b>7111808</b>
<b>RWEB 1050 FS</b>	100	500	1	<b>7111810</b>
<b>RWEB 1060 FS</b>	100	600	1	<b>7111812</b>

Reducer/stop-end for cable trays with side height 100 mm.

Including appropriate fastening material.

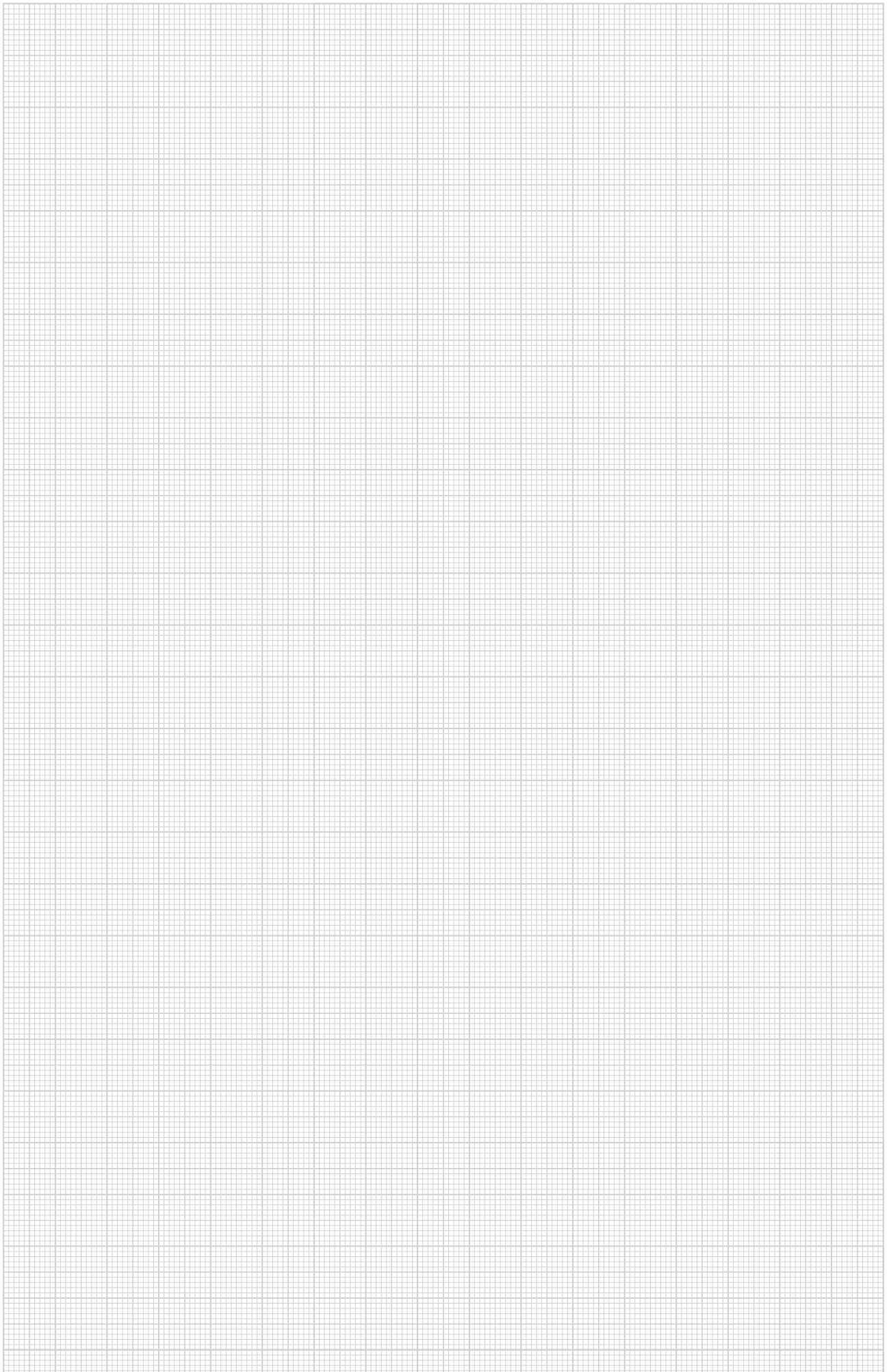

## Cable tray BKRS 110

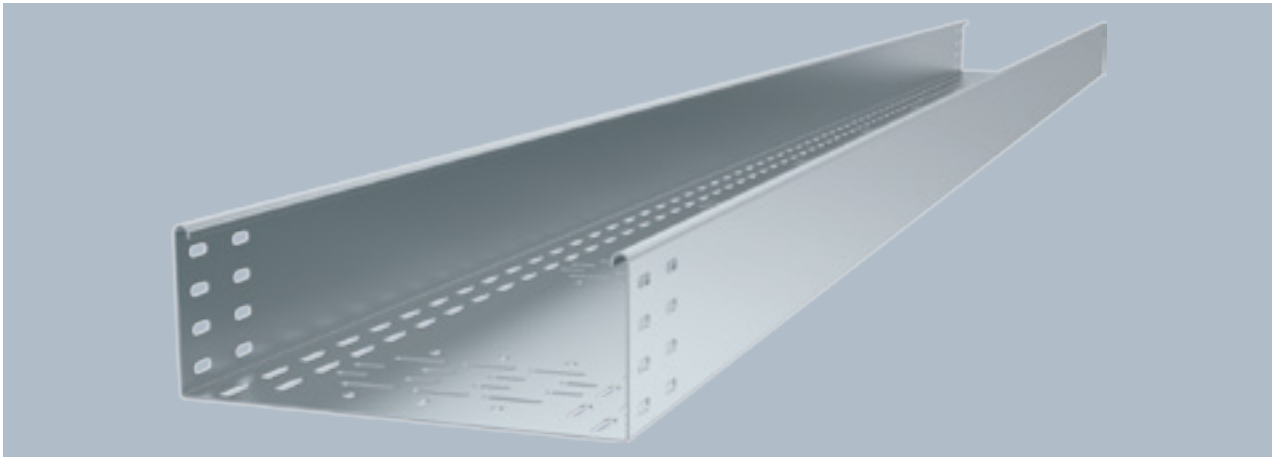

Type	Side height mm	Dim. H mm	Dim. B mm	Dim. L mm	Metal thickness mm	Min. ordering quantity	Item no.
BKRS 1110 FS	110	110	100	3000	2.00	3	6061981
BKRS 1120 FS	110	110	200	3000	2.00	3	6061983
BKRS 1130 FS	110	110	300	3000	2.00	3	6061985
BKRS 1140 FS	110	110	400	3000	2.00	3	6061987
BKRS 1150 FS	110	110	500	3000	2.00	3	6061989
BKRS 1160 FS	110	110	600	3000	2.00	3	6061991

Heavy-duty, walkable cable tray system BKRS with base perforation, in 110 mm side height.  
The cable tray has connector perforations on both sides. Straight connectors should be ordered separately and in the appropriate quantity.

Type	Dim. L mm	Dim. B mm	Dim. H mm	Metal thickness mm	Usable cross-section cm <sup>2</sup>
BKRS 1110 FS	3000	100	110	2.00	96
BKRS 1120 FS	3000	200	110	2.00	196
BKRS 1130 FS	3000	300	110	2.00	296
BKRS 1140 FS	3000	400	110	2.00	396
BKRS 1150 FS	3000	500	110	2.00	496
BKRS 1160 FS	3000	600	110	2.00	596

Dimensions

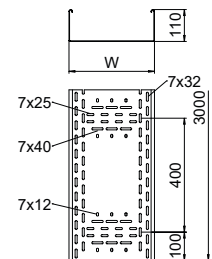

## Universal connector 110 FS

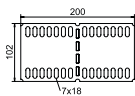

Type	Side height mm	Min. ordering quantity	Item no.
RUVK 110 FS	110	10	6067880

Universal connector for horizontal straight and angle connectors of walkable cable trays. In an angle state with additional cable protection through flattened edges. Including fastening material.

## Adjustable connector 110

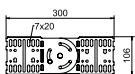
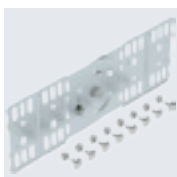

Type	Side height mm	Min. ordering quantity	Item no.
RGV 110 FS	110	10	7082037

Including appropriate fastening material.

St FS

### Barrier strip, Z-shaped 110

Type	Dim. H mm	Metal thickness mm	Length mm	Min. ordering quantity m	Item no.
<b>TSG110Z BKRS FS</b>	110	200	3000	3	<b>6062391</b>

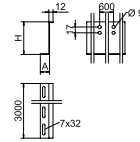

Barrier strip for the BKRS walkable cable tray system. Fastening with truss-head bolts M6 x 12 in the base perforation.

For widths of 200 mm or more, a barrier strip with a maximum compartment size of 220 mm should be used.  
For widths of 500 mm or more, two barrier strips with a maximum compartment size of 220 mm should be used.

St G

### Truss-head bolt with combination nut

Type	Dimension mm	Dim. L mm	Dim. d mm	Dim. D mm	Resistance grade	Min. ordering quantity Piece	Item no.
<b>FRSB 6x12 G</b>	M6x12	12	6	13,5	5,6	100	<b>6406130</b>

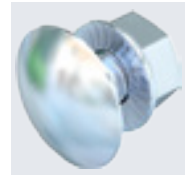
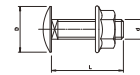

Hot galvanised truss-head bolt with square neck including electrogalvanised combination nut.

For universal fastening of construction components. Permitted use of the article only in dry atmospheres.

St FS

### Reducer/stop-end 110

Type	Side height mm	Dim. B mm	Min. ordering quantity Piece	Item no.
<b>RWEB 110 FS</b>	110	100	1	<b>7111096</b>
<b>RWEB 120 FS</b>	110	200	1	<b>7111207</b>
<b>RWEB 130 FS</b>	110	300	1	<b>7111304</b>
<b>RWEB 140 FS</b>	110	400	1	<b>7111428</b>
<b>RWEB 150 FS</b>	110	500	1	<b>7111509</b>
<b>RWEB 160 FS</b>	110	600	1	<b>7111740</b>

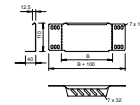

Reducer/stop-end for cable trays with side height 110 mm.

From a width of 150 mm, the perforated lower flange is provided.  
Including appropriate fastening material.

### Chequer plate cover DBKR

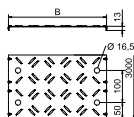

Type	Dim. B mm	Dim. b mm	Dim. L mm	Metal thickness mm	Min. ordering quantity m	Item no.
DBKR 100 FS	100	50	3000	3.30	3	6049119
DBKR 200 FS	200	50	3000	3.30	3	6049121
DBKR 300 FS	300	50	3000	3.30	3	6049123
DBKR 400 FS	400	50	3000	3.30	3	6049125
DBKR 500 FS	500	50	3000	3.30	3	6049127
DBKR 600 FS	600	50	3000	3.30	3	6049129
DBKR 100 DD	100	50	3000	3.30	3	6049140
DBKR 200 DD	200	50	3000	3.30	3	6049141
DBKR 300 DD	300	50	3000	3.30	3	6049142
DBKR 400 DD	400	50	3000	3.30	3	6049143
DBKR 500 DD	500	50	3000	3.30	3	6049144
DBKR 600 DD	600	50	3000	3.30	3	6049145
DBKR 100 FSK SGB	100	50	3000	3.30	3	6049095
DBKR 200 FSK SGB	200	50	3000	3.30	3	6049097
DBKR 300 FSK SGB	300	50	3000	3.30	3	6049099
DBKR 400 FSK SGB	400	50	3000	3.30	3	6049101
DBKR 500 FSK SGB	500	50	3000	3.30	3	6049103
DBKR 600 FSK SGB	600	50	3000	3.30	3	6049105

Chequer plate cover for the walkable cable tray system, type BKR. The cover thickness is comprised of 2.0 mm strip-galvanised sheet steel and a 1.3 mm chequer height. Pre-marked break-out openings at a spacing of 100 mm allow retroinstallation of a turn buckle. The covers are tested according to DIN 51130 and possess anti-slip class R11 and displacement space class V10. Cover fastenings are not part of the scope of delivery and can be ordered separately.

### Walkable cable cover

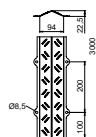

Type	Dim. B mm	Dim. b mm	Dim. L mm	Metal thickness mm	Min. ordering quantity m	Item no.
DDBKR FS	141	—	3000	2.00	3	6049229

Walkable cable cover for the protection of cables and lines on the floor. Lightweight roof, corrugated sheet steel, direct floor mounting in indoor areas.

St G

### Cover clamp

Type	Min. ordering quantity	Item no.
DK DBKR G	30	6049280

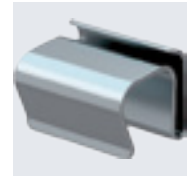
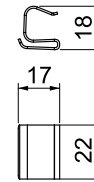

Cover clamp for rapid fastening of the chequer plate cover, type DBKR, on cable trays.  
We recommend using at least 6 cover clamps for 3 metres of chequer plate cover.

St FT

### Turn buckle for screwing

Type	Dim. B mm	Min. ordering quantity	Item no.
DRL H S BKRS FT	27	20	6065030

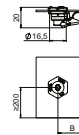

Cover support for the walkable BKRS cable tray system, as an additional support for covers. With rounded edges to protect the cables during routing.

St FS

### Cover support for walkable cable trays

Type	Dim. L mm	Min. ordering quantity	Item no.
DSTK 100 FS	96	10	6049244
DSTK 110 FS	109	10	6049245

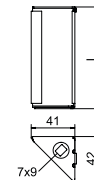

Cover support for the walkable BKRS cable tray system, as an additional support for covers. With rounded edges to protect the cables during routing.

St FS

### Cover lifter for chequer plate cover

Type	Length mm	Width mm	Height mm	Min. ordering quantity	Item no.
DH DBKR FS	200	150	33	1	6049285

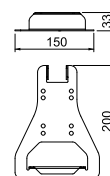

Position the cover lifters as pairs on the cover clamps and remove the chequer plate cover evenly. Repeat lengthways until the entire cover is removed.

Using the cover lifter, chequer plate covers installed with cover clamps can be dismantled quickly and simply.

Alternatively, the cover lifter can be used as a template for the connector perforation with cable trays cut during construction. For this, turn the cover lifter through 180° and position on the cable tray. Then use the perforation template appropriate to the side height.

## BKRS Z support

St FT

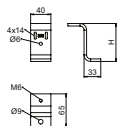

Type	Length mm	Width mm	Height mm	Min. order- ing quan- tity Piece	Item no.
ZST 100 BKRS FT	65	40	88	25	6044601
ZST 110 BKRS FT	65	40	75	25	6044603

Z support as a stand-off of the walkable BKRS cable tray system on the floor. Fastening of protection plates with chequer plate screws.

## Additional support for BKRS

St FS

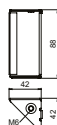

Type	Dim. L mm	Min. order- ing quan- tity Piece	Item no.
ZS BKRS 100	88	1	6049287
ZS BKRS 110	75	1	6049288

Additional support for the elevation of the walkable BKRS cable tray system on the floor. Required for elevations with Z supports ZST from a tray width of 500 mm. Fastening with flat head screw FKS 6x12 mm (item no. 6049246).

## Traverse for Z support for BKRS

St FS

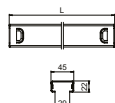

Type	Height mm	Min. order- ing quan- tity Piece	Item no.
TRV ZST 100 FS	22	1	6044423
TRV ZST 200 FS	22	1	6044426
TRV ZST 300 FS	22	1	6044429
TRV ZST 400 FS	22	1	6044431
TRV ZST 500 FS	22	1	6044434
TRV ZST 600 FS	22	1	6044437

Crossbar for Z-support to support walkable cable trays and prevent deflection with heavy cable loads. Connection with Z-support by snapping into place. Mounting of cable tray on traverse with FKS M6 screw through hole in Z-support.

## Flat-head screw with hexalobular internal

St G

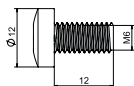

Type	Dimen- sion mm	Screw system	Min. order- ing quan- tity Piece	Item no.
FKS 6x12 G	M6x12	Torx	100	6049246

Flat-head screw with hexalobular internal to connect base and crossbeam of the symmetrical floor support BSS, to be used on walkable cable tray system BKRS.

St FS

### Protective panel

Type	Length mm	Height mm	Thickness mm	Min. order- ing quan- tity m	Item no.
<b>SB 100 BKS FS</b>	3000	78	1.5	3	<b>6049241</b>
<b>SB 110 BKS FS</b>	3000	65	1.5	3	<b>6049243</b>

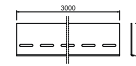

Protective panel, to be attached at the side as a collision guard for the walkable cable tray system. The protective panel can be installed on the Z supports using lens metal screws, type SPHS.

St G

### Lens head metal screw

Type	Dimen- sion mm	Min. order- ing quan- tity Piece	Item no.
<b>SPHS 4,8x9,5 G</b>	4,8x9,5	100	<b>6049248</b>

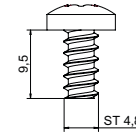

Metal screw with lens head according to shape F and Torx drive, according to DIN EN ISO 7049, to fasten protective panels to the Z supports for the walkable cable tray system.

## Symmetrical floor support, crossbeam

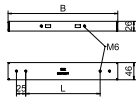

Type	Dim. B mm	Dim. L mm	Min. ordering quantity Piece	Item no.
<b>BSST 100 FS</b>	95	50	1	6044400
<b>BSST 200 FS</b>	195	100	1	6044402
<b>BSST 300 FS</b>	295	200	1	6044404
<b>BSST 400 FS</b>	395	300	1	6044406
<b>BSST 500 FS</b>	495	400	1	6044408
<b>BSST 600 FS</b>	595	500	1	6044410

Crossbeam of the symmetrical floor support for the BKRS system, suitable for base type BSSU 190. Depending on the type, can be used for walkable cable trays of width 100–600 mm. With threaded unions for cut-free mounting of cable trays. Fastening to base with 4x FKS M6 flat-head screws. Fastening material must be ordered separately.

## Symmetrical floor support, base

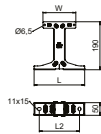

Type	Dim. B mm	Dim. L mm	Min. ordering quantity Piece	Item no.
<b>BSSU 190 1010 FS</b>	56	106	1	6044390
<b>BSSU 190 2030 FS</b>	130	200	1	6044392
<b>BSSU 190 4060 FS</b>	190	300	1	6044394

Base of the symmetrical floor support for the BKRS system, suitable for crossbeam type BSST. Depending on the type, can be used for walkable cable trays of width 100–600 mm. With threaded unions for mounting connection components, e.g. pipe clamps, as well as slots for floor mounting up to M10. Fastening material must be ordered separately.

## Flat-head screw with hexalobular internal

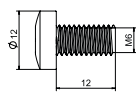

Type	Dimension mm	Screw system	Min. ordering quantity Piece	Item no.
<b>FKS 6x12 G</b>	M6x12	Torx	100	6049246

Flat-head screw with hexalobular internal to connect base and crossbeam of the symmetrical floor support BSS, to be used on walkable cable tray system BKRS.

## Drilling template, BKRS floor support

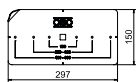

Type	Width mm	Item no.
<b>BSS BS</b>	150	6044609

Steel drilling template for the alignment and drilling of fastening holes for symmetrical floor supports of the BKRS walkable cable tray system. Suitable for support bases of type BSSU 190 1010/2030/4060.



### MS4121 mounting rail, slot 22 mm, perforated

St FS

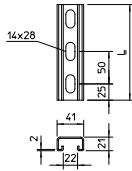

Type	Length mm	Material thickness mm	Min. ordering quantity Piece	Item no.
MS4121P0200FS	200	2	1	1122950
MS4121P0300FS	300	2	1	1122951
MS4121P0400FS	400	2	1	1122953
MS4121P0500FS	500	2	1	1122955
MS4121P0600FS	600	2	1	1122956

Heavy-duty C profile rail for individual installation of support constructions, e.g. for cable trays or as a panel for switchgear cabinets. Can also be used for cable routing, in conjunction with clamp clips with a U foot.

### MMS-plus MS mounting bolt tie, with flat pan head

St G

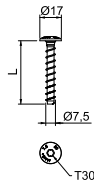

Type	Dimension mm	Dim. L mm	Drill hole Ø mm	Head Ø mm	Screw system	Min. ordering quantity Piece	Item no.
MMS+ MS 7.5x50	7,5x50	50	6	17	Torx	100	3498261

Bolt tie for direct mounting without additional anchors in cracked and uncracked concrete and masonry. With large round head to fasten mounting and profile rails. Torx drive T30. Construction product tested according to EAD and CE mark, with European Technical Assessment (ETA) and proof of suitability. Load-bearing capacities under fire loads proven up to fire resistance class R120.

### MMS-plus P round head bolt tie, with pan head

St G

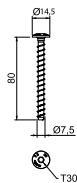

Type	Dimension mm	Anchor length mm	Drill hole Ø mm	Head Ø mm	Screw system	Min. ordering quantity Piece	Item no.
MMS+ P 7.5x80	7,5x80	80	6	14.5	Torx	50	3498272

Bolt tie for direct mounting without additional anchors in cracked and uncracked concrete and masonry. With round head for universal fastenings. Torx drive T30. Construction product tested according to EAD and CE mark, with European Technical Assessment (ETA) and proof of suitability. Load-bearing capacities under fire loads proven up to fire resistance class R120.

St FS



## Dust protection element and joint plate

Type	Dim. B mm	Min. ordering quantity Piece	Item no.
SSE SSLB 100 FS	100	1	6049290
SSE SSLB 200 FS	200	1	6049292
SSE SSLB 300 FS	300	1	6049294
SSE SSLB 400 FS	400	1	6049296
SSE SSLB 500 FS	500	1	6049298
SSE SSLB 600 FS	600	1	6049300



Dust protection element for use between chequer plate covers and aluminium chequer plates for walkable BKRS cable tray systems, as protection against dust and chips, etc.  
The component can alternatively be used as a joint plate in the walkable cable tray, to bridge construction interfaces.

St FS



## Variable dust protection element 100

Type	Width mm	Min. ordering quantity Piece	Item no.
VSSE 100 FS	109	10	6049310
VSSE 200 FS	209	10	6049314
VSSE 300 FS	309	10	6049316

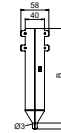

Variable dust protection element to extend the dust protection element of type SSE SSLB for walkable cable tray systems BKRS. Specially suited for cover joints that have been mitred. Toolless mounting.

PVC

## Edge protection strip

Type	For metal thickness mm	Dim. h mm	Colour	Length mm	Min. ordering quantity m	Item no.
KSB 4 PVC	1.5-4	15	Black	10000	10	6072895

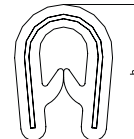

Edge protection strip with steel core for covering cut metal edges. Black version, UV-resistant.

St G

## Truss-head bolt with combination nut

Type	Dimension mm	Dim. L mm	Dim. d mm	Dim. D mm	Resistance grade	Min. ordering quantity Piece	Item no.
FRSB 6x12 G	M6x12	12	6	13.5	5.6	100	6406130
FRSB 6x20 G	M6x20	20	6	13.5	5.6	100	6406181

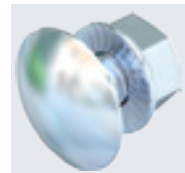
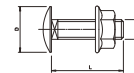

Hot galvanised truss-head bolt with square neck including electrogalvanised combination nut.  
For universal fastening of construction components. Permitted use of the article only in dry atmospheres.

## Clamp spring for stranded cables

St G

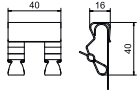

Type	Cross-section mm <sup>2</sup>	Min. ordering quantity Piece	Item no.
KFL G	35	50	6049273

Functional equipotential bonding of the cable support system can be created with the clamp spring. The clamp spring is clamped onto the edge of the cable tray and then the conductor cable is clamped into the intended support of the clamp spring. The clamp spring can accept conductor cables of between 10 and 35 mm<sup>2</sup> and should be mounted every 1,500 mm.

## Parallel connector Rd 8 mm, M10 x 30

Zn G

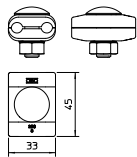

Type	Fit mm	Lightning current carrying capacity kA	Min. ordering quantity Piece	Item no.
260 8	Rd 8	H/100	50	5315700

• With flat, round bolt M10 x 30 and hexagonal nut, hot-dip galvanised steel

## Connection terminal, single

CuZn 37

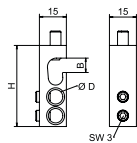
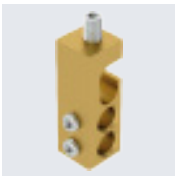

Type	Dim. H mm	Dim. B mm	Dim. D mm	Cross-section mm <sup>2</sup>	Min. ordering quantity Piece	Item no.
AKL 25 E	40	7	6.5	25	10	6049276
AKL 35 E	45	8	8	35	10	6049278

Simple connection terminal to accept 1 conductor cable, to create the protective equipotential bonding for cable support systems. Mounting on conductor cable, central in clamp spring.

## Connection terminal, double

CuZn 37

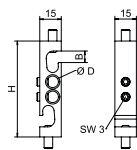
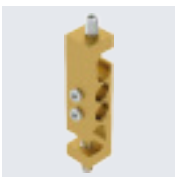

Type	Dim. H mm	Dim. B mm	Dim. D mm	Cross-section mm <sup>2</sup>	Min. ordering quantity Piece	Item no.
AKL 25 Z	60	7	6.5	25	10	6049277
AKL 35 Z	67	8	8	35	10	6049279

Double connection terminal to accept 2 conductor cables, to create the protective equipotential bonding for cable support systems. Can be used as a junction for branches and intersections. Mounting on conductor cable, central in clamp spring.

CuZn  
37

### Earthing terminal with fastening thread

Type	Dim. L mm	Dim. I mm	Cross-section mm <sup>2</sup>	Thread metric	Min. ordering quantity Piece	Item no.
<b>EKL 35 M6 ISK</b>	26	10	75	6	50	<b>6404016</b>

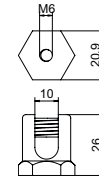

Earthing terminal for fastening the equipotential bonding conductor to the cable support system. M14 threaded pin, Allen drive with 6 mm across flats.  
Suitable for conductor cross sections of 25–75 mm<sup>2</sup>.

CuZn  
37

CE

### Connection terminal, single

Type	Cross-section mm <sup>2</sup>	Min. ordering quantity Piece	Item no.
<b>AKL 35 E DM</b>	35	10	<b>6049275</b>

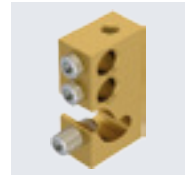
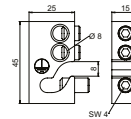

Simple connection terminal to accept 1 conductor cable, to create the protective equipotential bonding for cable support systems. Mounting on conductor cable, central in clamp spring.

CuZn  
37

CE

### Connection terminal for conductor rope

Type	Cross-section mm <sup>2</sup>	Min. ordering quantity Piece	Item no.
<b>AKL 95 Z DM</b>	120	10	<b>6049274</b>

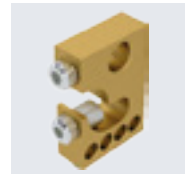
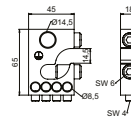

Cable duct, type LKM 20020

St FS

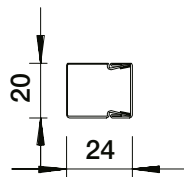

Type	Colour	Length mm	Min. ordering quantity m	Item no.
LKM20020FS	zinc	2000	2	6246966

Duct cover and base with base perforation. Equipotential bonding is guaranteed between the cover and the base without any additional aids.

Edge protection ring KSR 20020, for LKM cable duct type 20020

TPE  
CEUK CCA

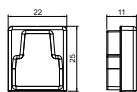
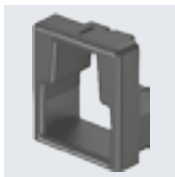

Type	Colour	Min. ordering quantity Piece	Item no.
LKM KSR20020	Graphite black	5	6249742

Edge protection ring for the open ends of LKM cable trunking.

Cable duct, type LKM 20030

St FS  
CEUK CCA E90

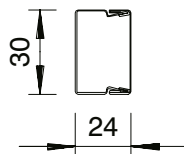

Type	Colour	Length mm	Min. ordering quantity m	Item no.
LKM20030FS	zinc	2000	2	6246974

Duct cover and base with base perforation. Equipotential bonding is guaranteed between the cover and the base without any additional aids. The LKM cable duct, type LKM 20030, has been tested for the maintenance of electrical function as a routing system according to DIN 4102 Part 12. Please note the cable types tested in the BSS fire protection systems division!

Edge protection ring KSR 20030, for LKM cable trunking type 20030

TPE  
CEUK CCA

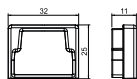
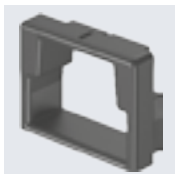

Type	Colour	Min. ordering quantity Piece	Item no.
LKM KSR20030	Graphite black	5	6249744

Edge protection ring for the open ends of LKM cable trunking.

St FS



Cable duct, type LKM 30030

Type	Colour	Length mm	Min. order- ing quan- tity m	Item no.
LKM30030FS	zinc	2000	2	6246985

Duct cover and base with base perforation.  
Equipotential bonding is guaranteed between the cover and the base without any additional aids.

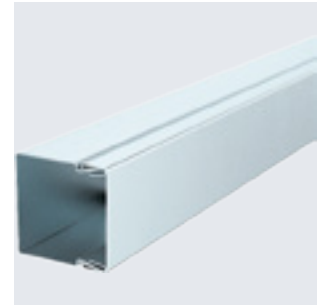
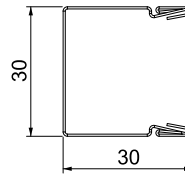

TPE



Edge protection ring KSR 30030, for LKM cable duct type 30030

Type	Colour	Min. order- ing quan- tity Piece	Item no.
LKM KSR30030	Graphite black	5	6249746

Edge protection ring for the open ends of LKM cable trunking.

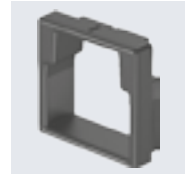
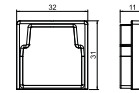

St FS

Cable duct, type LKM 40040

Type	Colour	Length mm	Min. order- ing quan- tity m	Item no.
LKM40040FS	zinc	2000	2	6246990

Duct cover and base with base perforation.  
Equipotential bonding is guaranteed between the cover and the base without any additional aids.

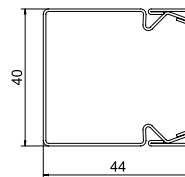

TPE



Edge protection ring KSR 40040, for LKM cable duct type 40040

Type	Colour	Min. order- ing quan- tity Piece	Item no.
LKM KSR40040	Graphite black	5	6249748

Edge protection ring for the open ends of LKM cable trunking.

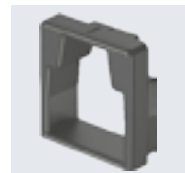
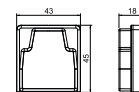

Cable duct, type LKM 40060

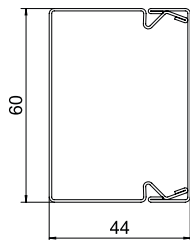
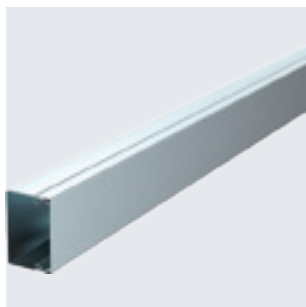

Type	Colour	Length mm	Min. order- ing quan- tity m	Item no.
LKM40060FS	zinc	2000	2	6247016

Duct cover and base with base perforation. Equipotential bonding is guaranteed between the cover and the base without any additional aids.

Edge protection ring KSR 40060, for LKM cable duct type 40060

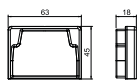
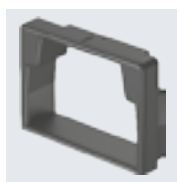

Type	Colour	Min. order- ing quan- tity Piece	Item no.
LKM KSR40060	Graphite black	5	6249750

Edge protection ring for the open ends of LKM cable trunking.

Cable trunking, type LKM 60060

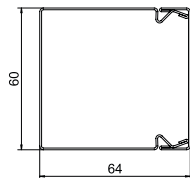

Type	Colour	Length mm	Min. order- ing quan- tity m	Item no.
LKM60060FS	zinc	2000	2	6247091

Trunking cover and base with base perforation. Equipotential bonding is guaranteed between the cover and the base without any additional aids. Note: LKM 60060 has no loop perforation in the base, a partition cannot be installed.

Edge protection ring KSR 60060, for LKM cable trunking type 60060

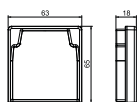
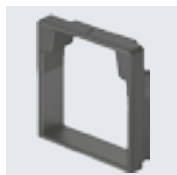

Type	Colour	Min. order- ing quan- tity Piece	Item no.
LKM KSR60060	Graphite black	5	6249752

Edge protection ring for the open ends of LKM cable trunking.

St FS



Cable trunking, type LKM 80080

Type	Colour	Length mm	Min. order- ing quan- tity m	Item no.
LKM80080FS	zinc	2000	2	6247194

Trunking cover and base with base perforation. Equipotential bonding is guaranteed between the cover and the base without any additional aids.

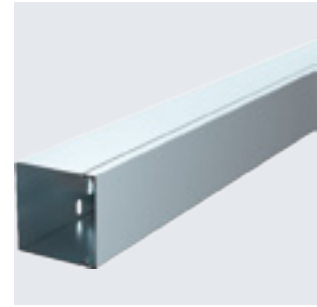
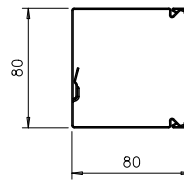

TPE



Edge protection ring KSR 80080, for LKM cable trunking type 80080

Type	Colour	Min. order- ing quan- tity Piece	Item no.
LKM KSR80080	Graphite black	5	6249762

Edge protection ring for the open ends of LKM cable trunking.

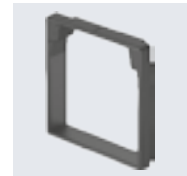
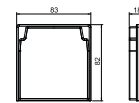

St FS

Cable duct, type LKM 60100

Type	Colour	Length mm	Min. order- ing quan- tity m	Item no.
LKM60100FS	zinc	2000	2	6247113

Duct cover and base with base perforation. Equipotential bonding is guaranteed between the cover and the base without any additional aids. The LKM cable duct, type LKM 60100, has been tested for the maintenance of electrical function as a routing system according to DIN 4102 Part 12. Please note the cable types tested in the BSS fire protection systems division!

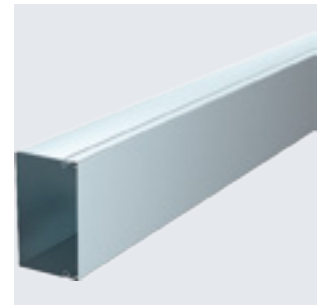
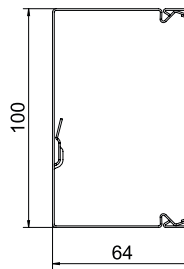

TPE



Edge protection ring KSR 60100, for LKM cable duct type 60100

Type	Colour	Min. order- ing quan- tity Piece	Item no.
LKM KSR60100	Graphite black	5	6249754

Edge protection ring for the open ends of LKM cable trunking.

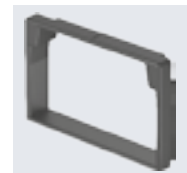
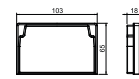

**OBO Bettermann Holding GmbH & Co. KG**  
Hüingser Ring 52  
58710 Menden  
GERMANY

**Customer Service Germany**  
Tel. +49 (0)2373 89-2000  
info@obo.de

[www.obo-bettermann.com](http://www.obo-bettermann.com)

© OBO Bettermann Order no. 9163211 02/2026 EN

**Building Connections**

